

Fairchild Fasteners

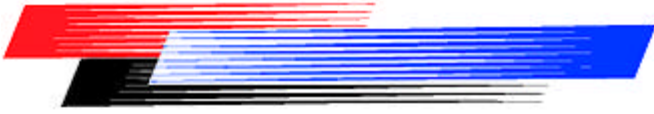

Santa Ana Operations

Ring Locked Inserts



INDEX

DESCRIPTION		PAGE
INSERT - RING LOCKED, COARSE INTERNAL AND COARSE EXTERNAL THREADS	RDJ100()	1
INSERT - RING LOCKED, WITH CBORE TOOLING	RDJ100() RJ100() & RDJ100()	2 3
HOLE PREPARATION	RJ100() & RDJ100()	4
INSERT - RING LOCKED, FINE INTERNAL AND COARSE EXTERNAL THREADS	RJ200()	5
INSERT - RING LOCKED, WITH CBORE TOOLING	RDJ200() RJ200() & RDJ200()	6 7
HOLE PREPARATION	RJ200() & RDJ200()	8
INSERT - RING LOCKED, FINE INTERNAL AND FINE EXTERNAL THREADS	RJ300()	9
INSERT - RING LOCKED, WITH CBORE TOOLING	RJ300() RJ300() & RDJ300()	10 11
HOLE PREPARATION	RJ300() & RDJ300()	12
INSERT - RING LOCKED, COURSE INTERNAL AND FINE EXTERNAL THREADS	RJ900()	13
INSERT - RING LOCKED, WITH CBORE TOOLING	RDJ900() RJ900() & RDJ900()	14 15
HOLE PREPARATION	RJ900() & RDJ900()	16
OVERSIZE REPLACEMENT	RJ()	17
OVERSIZE REPLACEMENT	RDJ()	18
INSERT - RING LOCKED, SOLID, FINE EXTERNAL THREADS	R1000()	19
INSER - RING LOCKED, SOLID COARSE EXTERNAL THREADS	R1100()	20
TOOLING	R1000() & R1100()	21
HOLE PREPARATION	R1000() & R1100()	22
INSERT - RING LOCKED, BLIND, FINE INTERNAL AND COARSE EXTERNAL THREADS	RJ1200()	23
INSER - RING LOCKED, BLIND, COARSE INTERNAL AND COARSE EXTERNAL THREADS	RJ2000()	24
TOOLING	RJ1200() & RJ2000()	25
HOLE PREPARATION	RJ1200() & RJ2000()	26
INSERT & LOCKRING - MATERIAL AND FINISHES	R(), RJ() RDJ() & RLRR()	27
INSTALLATION AND REMOVAL	R(), RJ() & RDJ()	28
INSERT - RING LOCKED, HYDRAULIC (150 PSI) TOOLING	RJ1700() RJ1700()	29 30
HOLE PREPARATION AND INSTALLATION	RJ1700()	31

INDEX

DESCRIPTION		PAGE
INSERT - RING LOCKED, HIGH STRENGTH TOOLING	RDJ3600()	32
HOLE PREPARATION AND DESIGN DATA	RDJ3600()	33
		34
INSERT - RING LOCKED, POLYIMIDE RESIN LOCK	05-13008()	35
TOOLING	05-13008()	36
HOLE PREPARATION	05-13008()	37
LOCKRING - MS51990-() TYPE DESIGN DATA	RLRR()	38
OVERSIZE REPLACEMENT	RLRR()	39
		40
LOCKRING - THIN DESIGN DATA	RL()	41
	RL()	42
LOCKRING - SELF BROACHING	RLH()	43
MS51991 VERSUS ROSAN INSERTS, MS51990 VERSUS ROSAN LOCKRINGS		44
TOOL - COUNTERBORE FOR ALUMINUM	RC()	45
TOOL - STEP DRILL FOR ALUMINUM	RCD()	46
TOOL - CHAMFERED STEP DRILL FOR ALUMINUM	RCDC()	47
TOOL - CHAMFERED STEP DRILL FOR MAGNESIUM	RCADC()	49
WRENCH	R1100W	51
LOCKRING DRIVE TOOL	R()D	52
LOCKRING DRIVE TOOL, WITH NYLON STOP	R()DN	53
LOCKRING DRIVE TOOL, SELF BROACHING LOCKRING	R()DH	54
ENGINEERING INFORMATION		55

TOOLING AND INSERT DIMENSIONS SHOWN IN THIS CATALOG ARE PROVIDED FOR ENVELOPE AND INSPECTION PURPOSES ONLY AND DO NOT INCLUDE DIMENSIONS NECESSARY FOR FABRICATION OF PRODUCT.

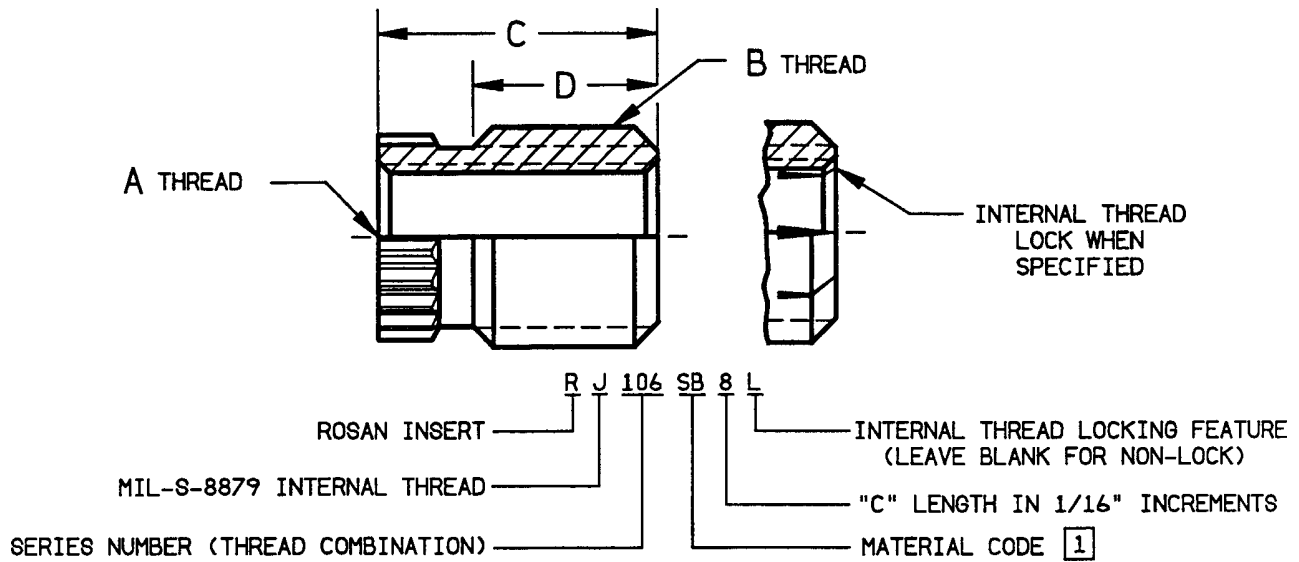

INSERT		LOCKRING		A INTERNAL THREAD UNJC-3B	B EXTERNAL THREAD [4]			C ±.015	D ±.015
ROSAN PART NUMBER	MILITARY PART NUMBER [8]	ROSAN PART NUMBER [7] REF	MILITARY PART NUMBER [7] [8] REF		SIZE	PITCH DIA	MINOR DIA		
RJ102SB4	MS51991-102	RLRR16SB5	MS51990-102P	.1120-40	.1900-24	.1633-.1648	.1334-.1407	.250	.150
RJ103SB5	MS51991-103	RLRR18SB6	MS51990-103P	.1380-32	.2160-24	.1893-.1908	.1594-.1667	.310	.190
RJ104SB6	MS51991-104	RLRR21SB6	MS51990-104P	.1640-32	.2500-20	.2178-.2198	.1824-.1909	.380	.250
RJ105SB7	MS51991-105	RLRR24SB7	MS51990-105P	.1900-24	.3125-18	.2769-.2789	.2373-.2468	.440	.290
RJ106SB8	MS51991-106	RLRR28SB8	MS51990-106P	.2500-20	.3750-16	.3347-.3372	.2906-.3011	.500	.330
RAJ107SB9	MS51991-107	RLRR33SB9	MS51990-107P	.3125-18	.5000-13	.4506-.4531	.3963-.4087	.560	.360
RJ108SB10	MS51991-108	RLRR38SB9	MS51990-108P	.3750-16	.5625-12	.5091-.5116	.4503-.4635	.620	.420
RJ109SB11	MS51991-109	RLRR47SB10	MS51990-109P	.4375-14	.6250-11	.5668-.5693	.5028-.5168	.690	.460
RJ110SB12	MS51991-110	RLRR56SB11	MS51990-110P	.5000-13	.7500-10	.6860-.6885	.6156-.6308	.750	.49

NOTES: UNLESS OTHERWISE SPECIFIED

[1] MATERIAL: 1117 steel per ASTM A108.

NOTE: These parts are available in other materials. Refer to page 27.

2. HEAT TREAT: None.

3. FINISH: Cadmium plate per QQ-P-416, TY II, CL3.

[4] The external thread has a special pitch diameter and minor diameter which installs into a MIL-S-8879 class 3B, MIL-S-7742 class 3B, or National class 3 tapped hole. Refer to page 55.

5. Inserts are installed and removed per page 28 or in accordance with MS51995.

6. Insert lengths shown are based on installation in 2024-T4 Aluminum and in such materials will accommodate tension loads up to the strength of a mating bolt heat treated to 145,000 PSI UTS. If this design criteria is required in parent materials of lower mechanical properties, longer insert lengths should be specified. Mating bolts should have a thread engagement of 1.5 diameters or if insert has a thread lock, the bolt should extend through the insert 2 pitches including chamfer.

[7] Mating lockring is not included with insert. It must be ordered separately.

[8] For other MS51991 inserts and MS51990 lockrings, see page 44.

**INSERT - RING LOCKED
COARSE INTERNAL AND COARSE EXTERNAL THREADS**

**RJ100()
SERIES**

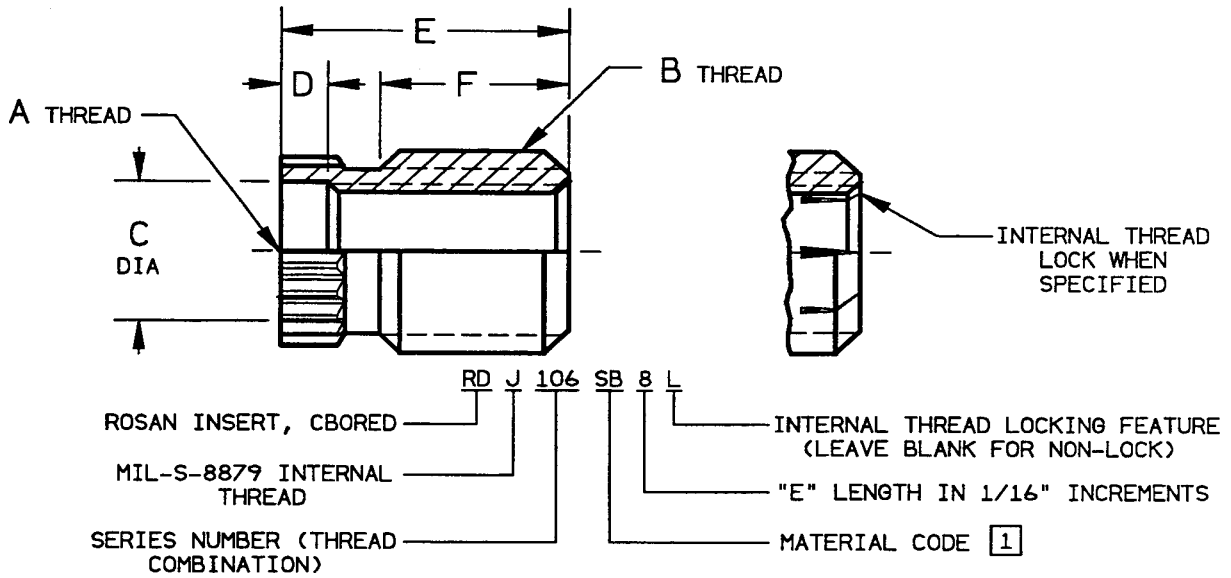

ROSAN INSERT PART NUMBER	LOCKRING		A INTERNAL THREAD UNJC-3B	B EXTERNAL THREAD [4]			C DIA ±.005	D ±.005	E ±.015	F ±.015
	ROSAN PART NUMBER [7] REF	MILITARY PART NUMBER [7][8] REF		SIZE	PITCH DIA	MINOR DIA				
	RDJ102SB4	RLRR16SB5		MS51990-102P	.1120-40	.1900-24				
RDJ103SB5	RLRR18SB6	MS51990-103P	.1380-32	.2160-24	.1893-.1908	.1594-.1667	.140	.040	.310	.190
RDJ104SB6	RLRR21SB6	MS51990-104P	.1640-32	.2500-20	.2178-.2198	.1824-.1909	.166	.047	.380	.250
RDJ105SB7	RLRR24SB7	MS51990-105P	.1900-24	.3125-18	.2769-.2789	.2373-.2468	.196	.062	.440	.290
RDJ106SB8	RLRR28SB8	MS51990-106P	.2500-20	.3750-16	.3347-.3372	.2906-.3011	.257	.080	.500	.330
RADJ107SB9	RLRR33SB9	MS51990-107P	.3125-18	.5000-13	.4506-.4531	.3963-.4087	.323	.095	.560	.360
RDJ108SB10	RLRR38SB9	MS51990-108P	.3750-16	.5625-12	.5091-.5116	.4503-.4635	.386	.100	.620	.420
RDJ109SB11	RLRR47SB10	MS51990-109P	.4375-14	.6250-11	.5668-.5693	.5028-.5168	.453	.100	.690	.460
RDJ110SB12	RLRR56SB11	MS51990-110P	.5000-13	.7500-10	.6860-.6885	.6156-.6308	.516	.109	.750	.490

NOTES: UNLESS OTHERWISE SPECIFIED

[1] MATERIAL: 1117 steel per ASTM A108.

NOTE: These parts are available in other materials. Refer to page 27.

2. HEAT TREAT: None.

3. FINISH: Cadmium plate per QQ-P-416, TY II, CL3.

[4] The external thread has a special pitch diameter and minor diameter which installs into a MIL-S-8879 class 3B, MIL-S-7742 class 3B, or National class 3 tapped hole. Refer to page 55.

5. Inserts are installed and removed per page 28.

6. Insert lengths shown are based on installation in 2024-T4 aluminum and in such materials will accommodate tension loads up to the strength of a mating bolt heat treated to 145,000 PSI UTS. If the design criteria is required in parent materials of lower mechanical properties, longer insert lengths should be specified. Mating bolts should have a thread engagement of 1.5 diameters or if insert has a thread lock, the bolt should extend through the insert 2 pitches including chamfer.

[7] Mating lockring is not included with insert. It must be ordered separately.

[8] For other MS51990 lockrings, see page 44.

**INSERT - RING LOCKED, WITH CBORE
COARSE INTERNAL AND COARSE EXTERNAL THREADS**

**RDJ100()
SERIES**



STEP DRILL



TAP



WRENCH



LOCKRING DRIVE TOOL

INSERT PART NUMBER REF	STEP DRILL PART NUMBER [1]		BASIC TAP SIZE [2] REF	WRENCH PART NUMBER	LOCKRING DRIVE TOOL PART NUMBER	REMOVAL DRILL SIZE [3] REF
	ALUMINUM	MAGNESIUM				
	RJ102SB4 and RDJ102SB4	RCDC16-149				
RJ103SB5 and RDJ103SB5	RCDC18-177	RCADC18-177	.2160-24UNC	R1103W	R103D	1/4
RJ104SB6 and RDJ104SB6	RCDC21-201	RCADC21-201	.2500-20UNC	R1104W	R104D	19/64
RJ105SB7 and RDJ105SB7	RCDC24-257	RCADC24-257	.3125-18UNC	R1105W	R105D	F
RJ106SB8 and RDJ106SB8	RCDC28-312	RCADC28-312	.3750-16UNC	R1106W	R106D	5/16
RAJ107SB9 and RADJ107SB9	RCDC33-422	RCADC33-422	.5000-13UNC	R1107XW	RA107D	V
RJ108SB10 and RDJ108SB10	RCDC38-484	RCADC38-484	.5625-12UNC	R1108W	R108D	29/64
RJ109SB11 and RDJ109SB11	RCDC47-535	RCADC47-535	.6250-11UNC	R1110W	R109D	9/16
RJ110SB12 and RDJ110SB12	RCDC56-656	RCADC56-656	.7500-10UNC	R1111W	R110D	11/1

NOTES: UNLESS OTHERWISE SPECIFIED

[1] Step drills are designed for thru hole drilling. When used to drill a blind hole, it may be necessary to grind the drill to suit the depth required.

[2] Taps are not supplied by Rosan. For specific thread information refer to hole preparation on page 4.

[3] Removal drills are not supplied by Rosan.

4. For tooling dimensional data refer to pages 45 thru 54.

**TOOLING,
INSERT - RING LOCKED**

**RJ100() AND RDJ100()
SERIES**

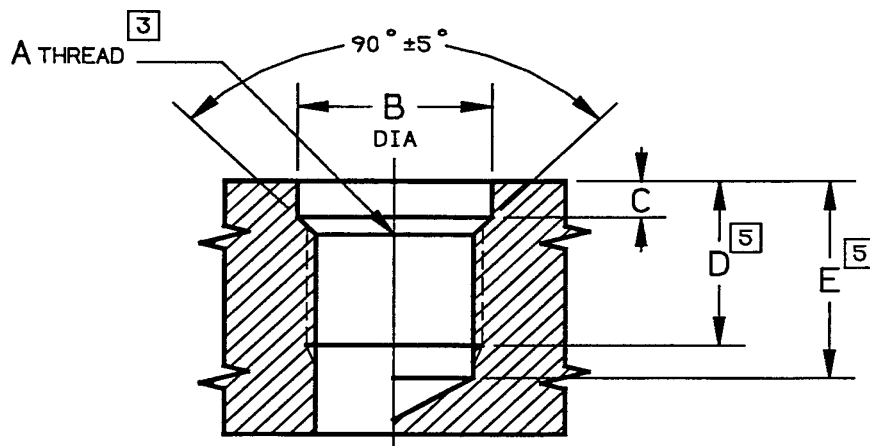

INSERT PART NUMBER REF	A THREAD CLASS 3B [3]	B DIA +.003 -.000 [1]		C +.030 -.000	D MIN FULL THREAD DEPTH [5]	E MIN DRILL DEPTH [5]	
		AL	MAG			PLUG TAP	BOTTOM TAP
RJ102SB4 and RDJ102SB4	.1900-24UNJC	.250	.258	.094	.285	.472	.389
RJ103SB5 and RDJ103SB5	.2160-24UNJC	.281	.291	.109	.345	.532	.449
RJ104SB6 and RDJ104SB6	.2500-20UNJC	.328	.337	.109	.415	.640	.540
RJ105SB7 and RDJ105SB7	.3125-18UNJC	.375	.381	.141	.475	.725	.614
RJ106SB8 and RDJ106SB8	.3750-16UNJC	.437	.448	.156	.535	.816	.691
RAJ107SB9 and RADJ107SB9	.5000-13UNJC	.515	.526	.172	.595	.941	.787
RJ108SB10 and RDJ108SB10	.5625-12UNJC	.593	.601	.172	.655	1.030	.863
RJ109SB11 and RDJ109SB11	.6250-11UNJC	.734	.747	.218	.725	1.134	.952
RJ110SB12 and RDJ110SB12	.7500-10UNJC	.875	.888	.203	.785	1.235	.103

NOTES: UNLESS OTHERWISE SPECIFIED

- [1] "B" diameter and minor diameter of thread to be concentric within .003 FIM.
- 2. When parent materia surface is not flat or normal to axis of hole, provide a spotface for proper lockring entry.
- [3] Thread as shown per MIL-S-8879 is preferred. Alternate thread per MIL-S-7742 class 3B or National class 3 is applicable when specified by design activity.
- 4. Remove all burrs and sharp edges.
- [5] "D" minimum full thread depth and "E" minimum drill depth are applicable for standard insert length shown only. For non standard lengths (see part number coding) "D and E" must change accordingly.

**HOLE PREPARATION,
INSERT - RING LOCKED**

**RJ100 AND RDJ100()
SERIES**

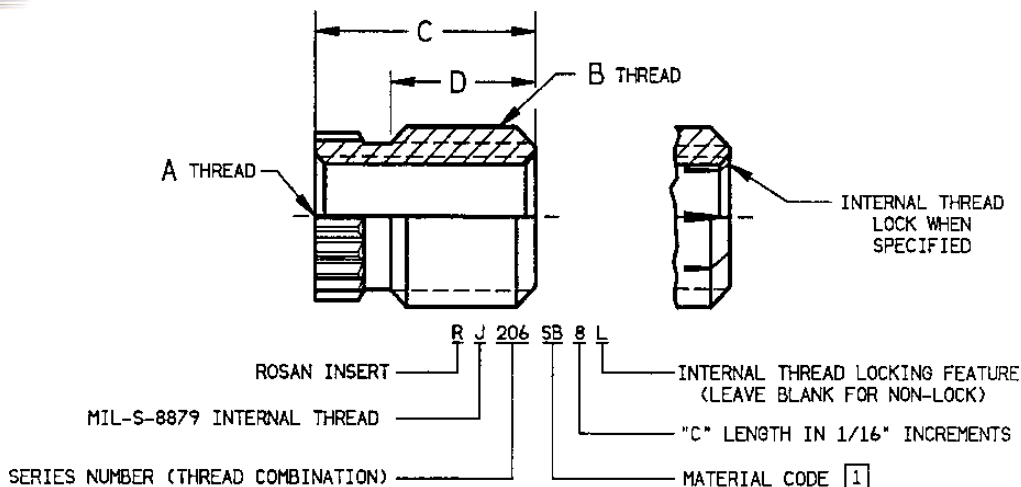

INSERT		LOCKRING		A INTERNAL THREAD UNJF-3B	B EXTERNAL THREAD [4]			C ±.015	D ±.015
ROSAN PART NUMBER	MILITARY PART NUMBER [8]	ROSAN PART NUMBER [7] REF	MILITARY PART NUMBER [7] [8] REF		SIZE	PITCH DIA	MINOR DIA		
RJ202SB4	MS51991-202	RLRR16SB5	MS51990-102P	.1120-48	.1900-24	.1633-.1648	.1334-.1407	.250	.150
RJ203SB5	MS51991-203	RLRR18SB6	MS51990-103P	.1380-40	.2160-24	.1893-.1908	.1594-.1667	.310	.190
RJ204SB6	MS51991-204	RLRR21SB6	MS51990-104P	.1640-36	.2500-20	.2178-.2198	.1824-.1909	.380	.250
RJ205SB7	MS51991-205	RLRR24SB7	MS51990-105P	.1900-32	.3125-18	.2769-.2789	.2373-.2468	.440	.290
RJ206SB8	MS51991-206	RLRR28SB8	MS51990-106P	.2500-28	.3750-16	.3347-.3372	.29060-.3011	.500	.330
RAJ207SB9	MS51991-207	RLRR33SB9	MS51990-107P	.3125-24	.5000-13	.4506-.4531	.3963-.4087	.560	.360
RJ208SB10	MS51991-208	RLRR38SB9	MS51990-108P	.3750-24	.5625-12	.5091-.5116	.4503-.4635	.620	.420
RJ209SB11	MS51991-209	RLRR47SB10	MS51990-109P	.4375-20	.6250-11	.5668-.5693	.5028-.5168	.690	.460
RJ210SB12	MS51991-210	RLRR56SB11	MS51990-110P	.5000-20	.7500-10	.6860-.6885	.6156-.6308	.750	.49

NOTES: UNLESS OTHERWISE SPECIFIED

[1] MATERIAL: 1117 steel per ASTM A108.

NOTE: These parts are available in other materials. Refer to page 27.

2. HEAT TREAT: None.

3. FINISH: Cadmium plate per QQ-P-416, TY II, CL3.

[4] The external thread has a special pitch diameter and minor diameter which installs into a MIL-S-8879 class 3B, MIL-S-7742 class 3B, or National class 3 tapped hole. Refer to page 55.

5. Inserts are installed and removed per page 28 or in accordance with MS51995.

6. Insert lengths shown are based on installation in 2024-T4 Aluminum and in such materials will accommodate tension loads up to the strength of a mating bolt heat treated to 145,000 PSI UTS. If the design criteria is required in parent materials of lower mechanical properties, longer insert lengths should be specified. Mating bolts should have a thread engagement of 1.5 diameters or if insert has a thread lock, the bolt should extend through the insert 2 pitches including chamfer.

[7] Mating lockring is not included with insert. It must be ordered separately.

[8] For other MS51991 inserts and MS51990 lockrings, see page 44.

**INSERT - RING LOCKED
FINE INTERNAL AND COARSE EXTERNAL THREADS**

**RJ200()
SERIES**

THIS PAGE INTENTIONALLY LEFT BLANK



STEP DRILL



TAP



WRENCH



LOCKRING DRIVE TOOL

INSERT PART NUMBER	STEP DRILL PART NUMBER [1]		BASIC TAP SIZE [2] REF	WRENCH PART NUMBER	LOCKRING DRIVE TOOL PART NUMBER	REMOVAL DRILL SIZE [3] REF]
	ALUMINUM	MAGNESIUM				
RJ202SB4 and RDJ202SB4	RCDC16-149	RCADC16-149	.1900-24UNC	R1102W	R102D	7/32
RJ203SB5 and RDJ203SB5	RCDC18-177	RCADC18-177	.2160-24UNC	R1103W	R103D	1/4
RJ204SB6 and RDJ204SB6	RCDC21-201	RCADC21-201	.2500-20UNC	R1104W	R104D	19/64
RJ205SB7 and RDJ205SB7	RCDC24-257	RCADC24-257	.3125-18UNC	R1105W	R205D	F
RJ206SB8 and RDJ206SB8	RCDC28-312	RCADC28-312	.3750-16UNC	R1106W	R206D	5/16
RAJ207SB9 and RADJ207SB9	RCDC33-422	RCADC33-422	.5000-13UNC	R1107XW	RA207D	V
RJ208SB10 and RDJ208SB10	RCDC38-484	RCADC38-484	.5625-12UNC	R1108W	R208D	29/64
RJ209SB11 and RDJ209SB11	RCDC47-535	RCADC47-535	.6250-11UNC	R1110W	R209D	9/16
RJ210SB12 and RDJ210SB12	RCDC56-656	RCADC56-656	.7500-10UNC	R1111W	R210D	11/16

NOTES: UNLESS OTHERWISE SPECIFIED

[1] Step drills are designed for thru hole drilling. When used to drill a blind hole, it may be necessary to grind the drill to suit the depth required.

[2] Taps are not supplied by Rosan. For specific thread information refer to hole preparation on page 8.

[3] Removal drills are not supplied by Rosan.

4. For tooling dimensional data refer to pages 45 thru 54.

**TOOLING,
INSERT - RING LOCKED**

**RJ200() AND RDJ200()
SERIES**

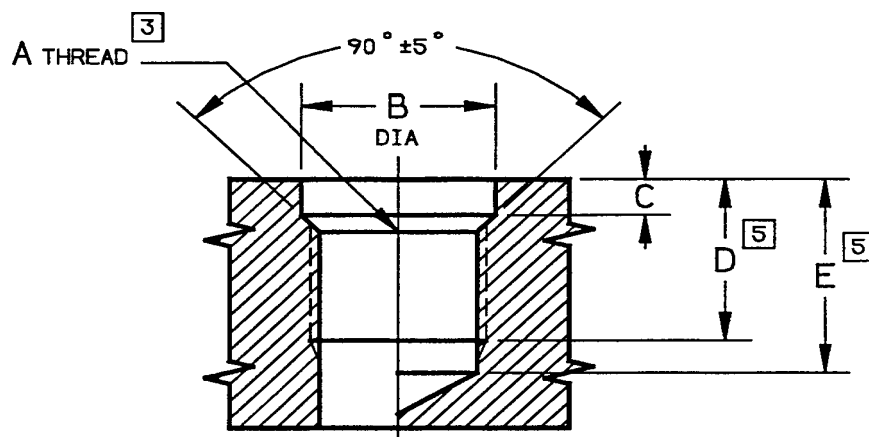

INSERT PART NUMBER REF	A THREAD CLASS 3B [3]	B DIA +.003 -.000 [1]		C +.030 -.000	D MIN FULL THREAD DEPTH [5]	E MIN DRILL DEPTH [5]	
		AL	MAG			PLUG TAP	BOTTOM TAP
		RJ202SB4 and RDJ202SB4	.1900-24UNJC			.250	.258
RJ203SB5 and RDJ203SB5	.2160-24UNJC	.281	.291	.109	.345	.532	.449
RJ204SB6 and RDJ204SB6	.2500-20UNJC	.328	.337	.109	.415	.640	.540
RJ205SB7 and RDJ205SB7	.3125-18UNJC	.375	.381	.141	.475	.725	.614
RJ206SB8 and RDJ206SB8	.3750-16UNJC	.437	.448	.156	.535	.816	.691
RAJ207SB9 and RADJ207SB9	.5000-13UNJC	.515	.526	.172	.595	.941	.787
RJ208SB10 and RDJ208SB10	.5625-12UNJC	.593	.601	.172	.655	1.030	.863
RJ209SB11 and RDJ209SB11	.6250-11UNJC	.734	.747	.218	.725	1.134	.952
RJ210SB12 and RDJ210SB12	.7500-10UNJC	.875	.888	.203	.785	1.235	1.035

NOTES: UNLESS OTHERWISE SPECIFIED

- [1] "B" diameter and minor diameter of thread to be concentric within .003 FIM.
- 2. When parent material surface is not flat or normal to axis of hole, provide a spotface for proper locking entry.
- [3] Thread as shown per MIL-S-8879 is preferred. Alternate thread per MIL-S-7742 class 3B or National class 3 is applicable when specified by design activity.
- 4. Remove all burrs and sharp edges.
- [5] "D" minimum full thread depth and "E" minimum drill depth are applicable for standard insert length shown only. For non standard lengths (see part number coding) "D" and "E" must change accordingly.

**HOLE PREPARATION,
INSERT - RING LOCKED**

**RJ200() AND RDJ200()
SERIES**

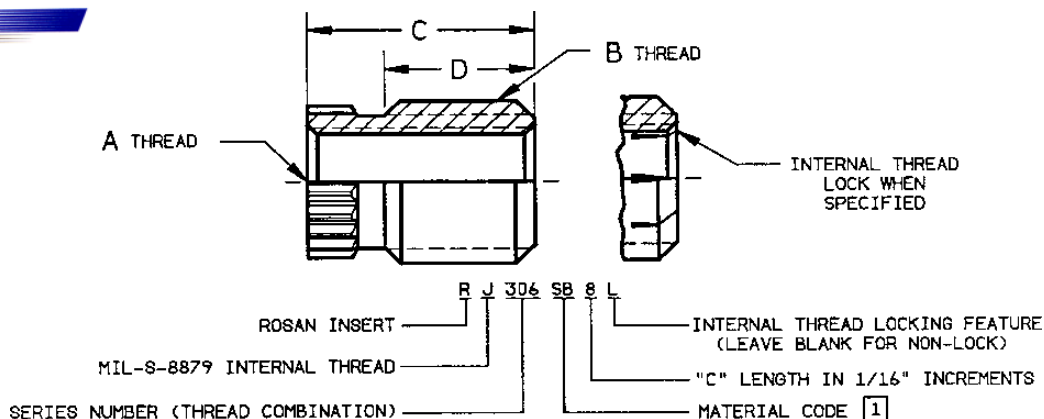

INSERT		LOCKRING		A INTERNAL THREAD UNJF-3B	B EXTERNAL THREAD			C ±.015	D ±.015
ROSAN PART NUMBER	MILITARY PART NUMBER [8]	ROSAN PART NUMBER [7] REF	MILITARY PART NUMBER [7][8] REF		[4]				
					SIZE	PITCH DIA	MINOR DIA		
RJ302SB4	—	RLRR16SB5	MS51990-102P	.1120-48	.1900-32	.1699-.1714	.1475-.1534	.250	.150
RJ303SB5	—	RLRR18SB6	MS51990-103P	.1380-40	.2160-28	.1931-.1946	.1674-.1740	.310	.190
RJ304SB6	—	RLRR21SB6	MS51990-104P	.1640-36	.2500-28	.2271-.2286	.2014-.2080	.380	.250
RJ305SB7	—	RLRR24SB7	MS51990-105P	.1900-32	.3125-24	.2858-.2873	.2559-.2632	.440	.290
RJ306SB8	—	RLRR28SB8	MS51990-106P	.2500-28	.3750-24	.3479-.3498	.3185-.3257	.500	.330
RJ307SB9	—	RLRR31SB9	—	.3125-24	.4375-20	.4053-.4073	.3700-.3784	.560	.380
RJ308SB10	—	RLRR38SB9	MS51990-108P	.3750-24	.5000-20	.4678-.4698	.4325-.4409	.620	.420
RJ309SB11	—	RLRR47SB10	MS51990-109P	.4375-20	.6250-18	.5894-.5914	.5498-.5593	.690	.460
RJ310SB12	—	RLRR56SB11	MS51990-110P	.5000-20	.7500-16	.7097-.7122	.6656-.6761	.750	.490
RJ311SB14	MS51991-311	RLRR64SB11	MS51990-111P	.5625-18	.8750-14	.8291-.8316	.7786-.7904	.880	.620
RJ312SB16	MS51991-312	RLRR72SB11	MS51990-112P	.6250-18	1.0000-14	.9541-.9566	.9036-.9154	1.000	.740
RJ312SB16F	MS51991-312.1	RLRR72SB11	MS51990-112P	.6250-18	1.0000-12	.9466-.9491	.8878-.9010	1.000	.740
RJ313SB18	MS51991-313	RLRR82SB12	MS51990-113P	.7500-16	1.1250-12	1.0716-1.0741	1.0128-1.0260	1.120	.800
RJ314SB20	MS51991-314	RLRR90SB12	MS51990-114P	.8750-14	1.2500-12	1.1966-1.1991	1.1378-1.1510	1.250	.900
RJ315SB22F	MS51991-315	RLRR100SB12	MS51990-115P	1.0000-12	1.3750-12	1.3216-1.3241	1.2628-1.2760	1.380	1.020
RJ315SB22	—	RLRR10SB12	MS51990-115P	1.0000-14UNJS	1.3750-12	1.3216-1.3241	1.2628-1.2760	1.380	1.02

NOTES: UNLESS OTHERWISE SPECIFIED

- [1] MATERIAL: 1117 steel per ASTM A108. NOTE: These parts are available in other materials. Refer to page 27.
- 2. HEAT TREAT: None.
- 3. FINISH: Cadmium plate per QQ-P-416, TY II, CL3.
- [4] The external thread has a special pitch diameter and minor diameter which installs into a MIL-S-8879 class 3B, MIL-S-7742 class 3B, or National class 3 tapped hole. Refer to page 55.
- 5. Inserts are installed and removed per page 28 or in accordance with MS51995 as applicable.
- 6. Insert lengths shown are based on installation in 2024-T4 Aluminum and in such materials will accommodate tension loads up to the strength of a mating bolt heat treated to 145,000 PSI UTS. If this design criteria is required in parent materials of lower mechanical properties, longer insert lengths should be specified. Mating bolts should have a thread engagement of 1.5 diameters or if insert has a thread lock, the bolt should extend through the insert 2 pitches including chamfer.
- [7] Mating lockring is not included with insert. It must be ordered separately.
- [8] For other MS51991 inserts and MS51990 lockrings, see page 44.

**INSERT - RING LOCKED
FINE INTERNAL AND FINE EXTERNAL THREADS**

**RJ300()
SERIES**

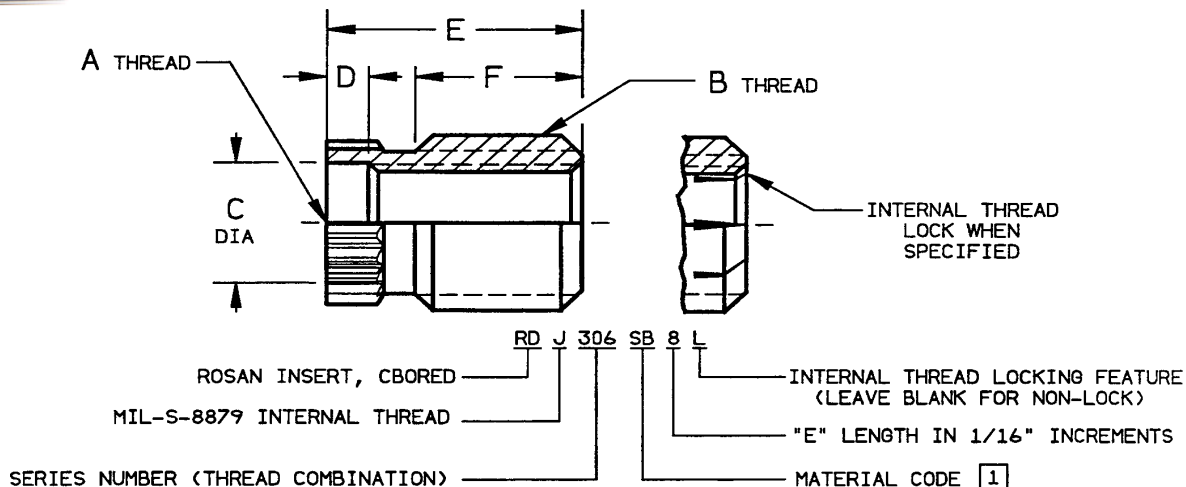

ROSAN INSERT PART NUMBER	LOCKRING		A INTERNAL THREAD UNJF-3B	B EXTERNAL THREAD [4]			C DIA ±.005	D ±.005	E ±.015	F ±.015
	ROSAN PART NUMBER [7] REF	MILITARY PART NUMBER [7][8] REF		SIZE	PITCH DIA	MINOR DIA				
RDJ302SB4	RLRR16SB5	MS51990-102P	.1120-48	.1900-32	.1699-.1714	.1475-.1534	.113	.040	.250	.150
RDJ303SB5	RLRR18SB6	MS51990-103P	.1380-40	.2160-28	.1931-.1946	.1674-.1740	.140	.040	.310	.190
RDJ304SB6	RLRR21SB6	MS51990-104P	.1640-36	.2500-28	.2271-.2286	.2014-.2080	.166	.047	.380	.250
RDJ305SB7	RLRR24SB7	MS51990-105P	.1900-32	.3125-24	.2858-.2873	.2559-.2632	.196	.062	.440	.290
RDJ306SB8	RLRR28SB8	MS51990-106P	.2500-28	.3750-24	.3479-.3298	.3185-.3257	.257	.080	.500	.330
RDJ307SB9	RLRR31SB9	—	.3125-24	.4375-20	.4053-.4073	.3700-.3784	.323	.095	.560	.380
RDJ308SB10	RLRR38SB9	MS51990-108P	.3750-24	.5000-20	.4678-.4698	.4325-.4409	.386	.100	.620	.420
RDJ309SB11	RLRR47SB10	MS51990-109P	.4375-20	.6250-18	.5894-.5914	.5498-.5593	.453	.100	.690	.460
RDJ310SB12	RLRR56SB11	MS51990-110P	.5000-20	.7500-16	.7097-.7122	.6656-.6761	.516	.109	.750	.490
RDJ311SB14	RLRR64SB11	MS51990-111P	.5625-18	.8750-14	.8291-.8316	.7786-.7904	.578	.125	.880	.620
RDJ312SB16	RLRR72SB11	MS51990-112P	.6250-18	1.0000-14	.9541-.9566	.9036-.9154	.640	.140	1.000	.740
RDJ313SB18	RLRR82SB12	MS51990-113P	.7500-16	1.1250-12	1.0716-1.0741	1.0128-1.0260	.765	.156	1.120	.800
RDJ314SB20	RLRR90SB12	MS51990-114P	.8750-14	1.2500-12	1.1966-1.1991	1.1378-1.1510	.890	.178	1.250	.90

NOTES: UNLESS OTHERWISE SPECIFIED

- [1] MATERIAL: 1117 steel per ASTM A108. NOTE: These parts are available in other materials. Refer to page 27.
- 2. HEAT TREAT: None.
- 3. FINISH: Cadmium plate per QQ-P-416, TYII, CL3.
- [4] The external thread has a special pitch diameter and minor diameter which installs into a MIL-S-8879 class 3B, MIL-S-7742 class 3B, or National class 3 tapped hole. Refer to page 55.
- 5. Inserts are installed and removed per page 28.
- 6. Insert lengths shown are based on installation in 2024-T4 Aluminum and in such materials will accommodate tension loads up to the strength of a mating bolt heat treated to 145,000 PSI UTS. If the design criteria is required in parent materials of lower mechanical properties, longer insert lengths should be specified. Mating bolts should have a thread engagement of 1.5 diameters or if insert has a thread lock, the bolt should extend through the insert 2 pitches including chamfer.
- [7] Mating lockring is not included with insert. It must be ordered separately.
- [8] For other MS51990 lockrings, see page 44.

**INSERT - RING LOCKED, WITH CBORE
FINE INTERNAL AND FINE EXTERNAL THREADS**

**RDJ300()
SERIES**



STEP DRILL



TAP



WRENCH



LOCKRING DRIVE TOOL

INSERT PART NUMBER REF	STEP DRILL PART NUMBER [1]		BASIC TAP SIZE [2] REF	WRENCH PART NUMBER	LOCKRING DRIVE TOOL PART NUMBER	REMOVAL DRILL SIZE [3] REF
	ALUMINUM	MAGNESIUM				
RJ302SB4 and RDJ302SB4	RCDC16-159	RCADC16-159	.1900-32UNF	R1102W	R102D	7/32
RJ303SB5 and RDJ303SB5	RCDC18-180	RCADC18-180	.2160-28UNF	R1103W	R103D	1/4
RJ304SB6 and RDJ304SB6	RCDC21-213	RCADC21-213	.2500-28UNF	R1104W	R104D	19/64
RJ305SB7 and RDJ305SB7	RCDC24-272	RCADC24-272	.3125-24UNF	R1105W	R205D	F
RJ306SB8 and RDJ306SB8	RCDC28-332	RCADC28-332	.3750-24UNF	R1106W	R206D	5/16
RJ307SB9 and RDJ307SB9	RCDC31-386	RCADC31-386	.4375-20UNF	R1107W	R207D	U
RJ308SB10 and RDJ308SB10	RCDC38-453	RCADC38-453	.5000-20UNF	R1108W	R208D	29/64
RJ309SB11 and RDJ309SB11	RCDC47-569	RCADC47-569	.6250-18UNF	R1110W	R209D	9/16
RJ310SB12 and RDJ310SB12	RCDC56-687	RCADC56-687	.7500-16UNF	R1111W	R210D	11/16
RJ311SB14 and RDJ311SB14	RCDC64-802	RCADC64-802	.8750-14UNF	R1112W	R211D	25/32
RJ312SB16 and RDJ312SB16	RCDC72-927	RCADC72-927	1.0000-14UNS	R1113W	R212D	57/64
RJ312SB16F	RCDC72-922	RCADC72-922	1.0000-12UNF	R1113W	R212D	57/64
RJ313SB18 and RDJ313SB18	RCDC82-1043	RCADC82-1043	1.1250-12UNF	R1114W	R213D	1 1/32
RJ314SB20 and RDJ314SB20	RCDC90-1165	RCADC90-1165	1.2500-12UNF	R1115W	R214D	1 11/64
RJ315SB22F	RCDC100-1289	RCADC100-1289	1.3750-12UNF	R1116W	R315D	1 9/32
RJ315SB22	RCDC100-1289	RCADC100-1289	1.3750-12UNF	R1116W	R215D	1 9/32

NOTES: UNLESS OTHERWISE SPECIFIED

[1] Step drills are designed for thru hole drilling. When used to drill a blind hole, it may be necessary to grind the drill to suit the depth required.

[2] Taps are not supplied by Rosan. For specific thread information refer to hole preparation on page 4.

[3] Removal drills are not supplied by Rosan.

4. For tooling dimensional data refer to pages 45 thru 54.

**TOOLING,
INSERT - RING LOCKED**

**RJ300() AND RDJ300()
SERIES**

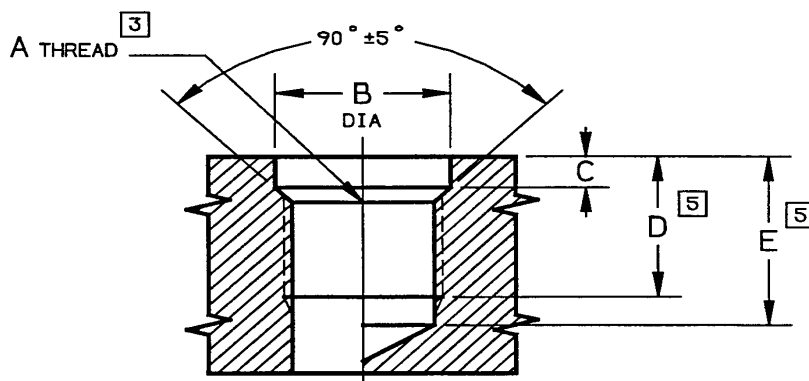

INSERT PART NUMBER REF	A THREAD CLASS 3B [3]	B DIA +.003 -.000 [1]		C +.030 -.000	D MIN FULL THREAD DEPTH [5]	E MIN DRILL DEPTH [5]	
		AL	MAG			PLUG TAP	BOTTOM TAP
RJ302SB4 and RDJ302SB4	.1900-32UNJF	.250	.258	.094	.285	.426	.363
RJ303SB5 and RDJ303SB5	.2160-28UNJF	.281	.291	.109	.345	.506	.434
RJ304SB6 and RDJ304SB6	.2500-28UNJF	.328	.337	.109	.415	.576	.504
RJ305SB7 and RDJ305SB7	.3125-24UNJF	.375	.381	.141	.475	.663	.579
RJ306SB8 and RDJ306SB8	.3750-24UNJF	.437	.448	.156	.535	.723	.639
RJ307SB9 and RDJ307SB9	.4375-20UNJF	.484	.495	.172	.595	.820	.720
RJ308SB10 and RDJ308SB10	.5000-20UNJF	.593	.601	.172	.655	.880	.780
RJ309SB11 and RDJ309SB11	.6250-18UNJF	.734	.747	.188	.725	.975	.864
RJ310SB12 and RDJ310SB12	.7500-16UNJF	.875	.888	.203	.785	1.066	.941
RJ311SB14 and RDJ311SB14	.8750-14UNJF	1.000	1.015	.203	.915	1.236	1.094
RJ312SB16 and RDJ312SB16	1.0000-14UNJS	1.125	1.139	.203	1.035	1.356	1.214
RJ312SB16F	1.0000-12UNJF	1.125	1.139	.203	1.1035	1.410	1.243
RJ313SB18 and RDJ313SB18	1.1250-12UNJF	1.281	1.298	.219	1.155	1.530	1.363
RJ314SB20 and RDJ314SB20	1.2500-12UNJF	1.406	1.427	.219	1.285	1.660	1.493
RJ315SB22F	1.3750-12UNJF	1.562	1.579	.219	1.415	1.790	1.623
RJ315SB22	1.3750-12UNJF	1.562	1.579	.219	1.415	1.790	1.623

NOTES: UNLESS OTHERWISE SPECIFIED

- [1] "B" diameter and minor diameter of thread to be concentric within .003 FIM.
- 2. When parent material surface is not flat or normal to axis of hole, provide a spotface for proper locking entry.
- [3] Thread as shown per MIL-S-8879 is preferred. Alternate thread per MIL-S-7742 class 3B or National class 3 is applicable when specified by design activity.
- 4. Remove all burrs and sharp edges.
- [5] "D" minimum full thread depth and "E" minimum drill depth are applicable for standard insert length shown only. For non standard lengths (see part number coding) "D" and "E" must change accordingly.

**HOLE PREPARATION,
INSERT - RING LOCKED**

**RJ300() AND RDJ300()
SERIES**

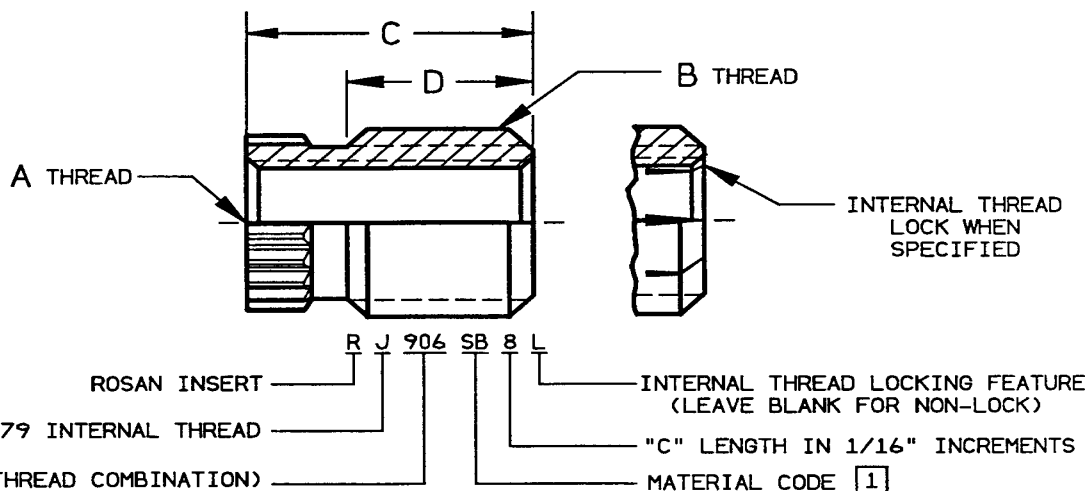

ROSAN INSERT PART NUMBER	LOCKRING		A INTERNAL THREAD CLASS-3B	B EXTERNAL THREAD [4]			C ±.015	D ±.015
	ROSAN PART NUMBER REF	MILITARY PART NUMBER [7][8] REF		SIZE	PITCH DIA	MINOR DIA		
	RJ902SB4	RLRR16SB5		MS51990-102P	.1120-40UNJC	.1900-32		
RJ903SB5	RLRR18SB6	MS51990-103P	.1380-32UNJC	.2160-28	.1931-.1946	.1674-.1740	.310	.190
RJ904SB6	RLRR21SB6	MS51990-104P	.1640-32UNJC	.2500-28	.2271-.2286	.2014-.2080	.380	.250
RJ905SB7	RLRR24SB7	MS51990-105P	.1900-24UNJC	.3125-24	.2858-.2873	.2559-.2632	.440	.290
RJ906SB8	RLRR28SB8	MS51990-106P	.2500-20UNJC	.3750-24	.3479-.3498	.3185-.3257	.500	.330
RJ907SB9	RLRR31SB9	—	.3125-18UNJC	.4375-20	.4053-.4073	.3700-.3784	.560	.380
RJ908SB10	RLRR38SB9	MS51990-108P	.3750-16UNJC	.5000-20	.4678-.4698	.4325-.4409	.620	.420
RJ909SB11	RLRR47SB10	MS51990-109P	.4375-14UNJC	.6250-18	.5894-.5914	.5498-.5593	.690	.460
RJ910SB12	RLRR56SB11	MS51990-110P	.5000-13UNJC	.7500-16	.7097-.7122	.6656-.6761	.750	.490
RJ911SB14	RLRR64SB11	MS51990-111P	.5625-12UNJC	.8750-14	.8291-.8316	.7786-.7904	.880	.620
RJ912SB16	RLRR72SB11	MS51990-112P	.6250-11UNJC	1.0000-14	.9541-.9566	.9036-.9154	1.000	.740
RJ913SB18	RLRR82SB12	MS51990-113P	.7500-10UNJC	1.1250-12	1.0716-1.0741	1.0128-1.0260	1.120	.800
RJ914SB20	RLRR90SB12	MS51990-114P	.8750-9UNJC	1.2500-12	1.1966-1.1991	1.1378-1.1510	1.250	.900
RJ915SB22	RLRR100SB12	MS51990-115P	1.0000-8UNJC	1.3750-12	1.3216-1.3241	1.2628-1.2760	1.380	1.02

NOTES: UNLESS OTHERWISE SPECIFIED

- [1] MATERIAL: 1117 steel per ASTM A108. NOTE: These parts are available in other materials. Refer to page 27.
- 2. HEAT TREAT: None.
- 3. FINISH: Cadmium plate per QQ-P-416, TY II, CL3.
- [4] The external thread has a special pitch diameter and minor diameter which installs into a MIL-S-8879 class 3B, MIL-S-7742 class 3B, or National class 3 tapped hole. Refer to page 55.
- 5. Inserts are installed and removed per page 28.
- 6. Insert lengths shown are based on installation in 2024-T4 Aluminum and in such materials will accommodate tension loads up to the strength of a mating bolt heat treated to 145,000 PSI UTS. If this design criteria is required in parent materials of lower mechanical properties, longer insert lengths should be specified. Mating bolts should have a thread engagement of 1.5 diameters or if insert has a thread lock, the bolt should extend through the insert 2 pitches including chamfer.
- [7] Mating lockring is not included with insert. It must be ordered separately.
- [8] For other MS51990 lockrings, see page 44.

**INSERT - RING LOCKED
COARSE INTERNAL AND FINE EXTERNAL THREADS**

**RJ900()
SERIES**

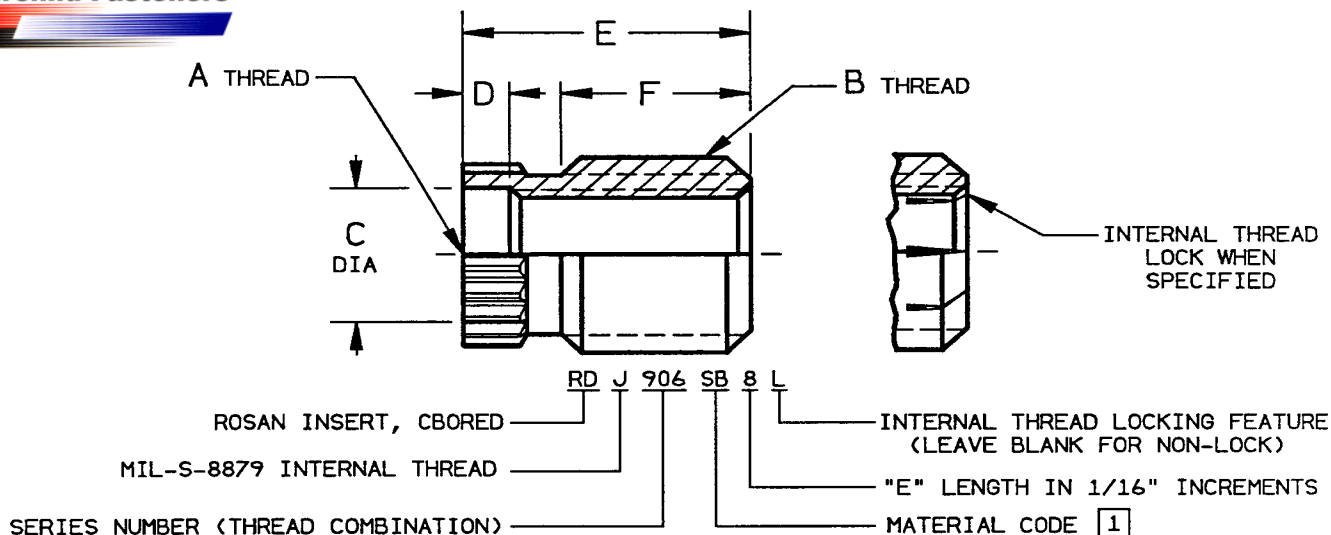

ROSAN INSERT PART NUMBER	LOCKRING		A INTERNAL THREAD CLASS-3B	B EXTERNAL THREAD [4]			C DIA ±.005	D ±.005	E ±.015	F ±.015
	ROSAN PART NUMBER [7] REF	MILITARY PART NUMBER [7][8] REF		SIZE	PITCH DIA	MINOR DIA				
RDJ902SB4	RLRR16SB5	MS51990-102P	.1120-40UNJC	.1900-32	.1699-.1714	.1475-.1534	.113	.040	.250	.150
RDJ903SB5	RLRR18SB6	MS51990-103P	.1380-32UNJC	.2160-28	.1931-.1946	.1674-.1740	.140	.040	.310	.190
RDJ904SB6	RLRR21SB6	MS51990-104P	.1640-32UNJC	.2500-28	.2271-.2286	.2014-.2080	.166	.047	.380	.250
RDJ905SB7	RLRR24SB7	MS51990-105P	.1900-24UNJC	.3125-24	.2858-.2873	.2559-.2632	.196	.062	.440	.290
RDJ906SB8	RLRR28SB8	MS51990-106P	.2500-20UNJC	.3750-24	.3479-.3498	.3185-.3257	.257	.080	.500	.330
RDJ907SB9	RLRR31SB9	—	.3125-18UNJC	.4375-20	.4053-.4073	.3700-.3784	.323	.095	.560	.380
RDJ908SB10	RLRR38SB9	MS51990-108P	.3750-16UNJC	.5000-20	.4678-.4698	.4325-.4409	.386	.100	.620	.420
RDJ909SB11	RLRR47SB10	MS51990-109P	.4375-14UNJC	.6250-18	.5894-.5914	.5498-.5593	.453	.100	.690	.460
RDJ910SB12	RLRR56SB11	MS51990-110P	.5000-13UNJC	.7500-16	.7097-.7122	.6656-.6761	.516	.109	.750	.490
RDJ911SB14	RLRR64SB11	MS51990-111P	.5625-12UNJC	.8750-14	.8291-.8316	.7786-.7904	.578	.125	.880	.620
RDJ912SB16	RLRR72SB11	MS51990-112P	.6250-11UNJC	1.0000-14	.9541-.9566	.9036-.9154	.640	.140	1.000	.740
RDJ913SB18	RLRR82SB12	MS51990-113P	.7500-10UNJC	1.1250-12	1.0716-1.0741	1.0128-1.0260	.765	.156	1.120	.80

NOTES: UNLESS OTHERWISE SPECIFIED

- [1] MATERIAL: 1117 steel per ASTM A108. NOTE: These parts are available in other materials. Refer to page 27.
- 2. HEAT TREAT: None.
- 3. FINISH: Cadmium plate per QQ-P-416, TY II, CL3.
- [4] The external thread has a special pitch diameter and minor diameter which installs into a MIL-S-8879 class 3B, MIL-S-7742 class 3B, or National class 3 tapped hole. Refer to page 55.
- 5. Inserts are installed and removed per page 28.
- 6. Insert lengths shown are based on installation in 2024-T4 Aluminum and in such materials will accommodate tension loads up to the strength of a mating bolt heat treated to 145,000 PSI UTS. If the design criteria is required in parent materials of lower mechanical properties, longer insert lengths should be specified. Mating bolts should have a thread engagement of 1.5 diameters or if insert has a thread lock, the bolt should extend through the insert 2 pitches including chamfer.
- [7] Mating lockring is not included with insert. It must be ordered separately.
- [8] For other MS51990 lockrings, see page 44.

INSERT - RING LOCKED, WITH CBORE
COARSE INTERNAL AND FINE EXTERNAL THREADS

RDJ900()
SERIES



STEP DRILL



TAP



WRENCH



LOCKRING DRIVE TOOL

INSERT PART NUMBER REF	STEP DRILL PART NUMBER [1]		BASIC TAP SIZE [2] REF	WRENCH PART NUMBER	LOCKRING DRIVE TOOL PART NUMBER	REMOVAL DRILL SIZE [3] REF
	ALUMINUM	MAGNESIUM				
RJ902SB4 and RDJ902SB4	RCDC16-159	RCADC16-159	.1900-32UNF	R1102W	R102D	7/32
RJ903SB5 and RDJ903SB5	RCDC18-180	RCADC18-180	.2160-28UNF	R1103W	R103D	1/4
RJ904SB6 and RDJ904SB6	RCDC21-213	RCADC21-213	.2500-28UNF	R1104W	R104D	19/64
RJ905SB7 and RDJ905SB7	RCDC24-272	RCADC24-272	.3125-24UNF	R1105W	R105D	F
RJ906SB8 and RDJ906SB8	RCDC28-332	RCADC28-332	.3750-24UNF	R1106W	R106D	5/16
RJ907SB9 and RDJ907SB9	RCDC31-386	RCADC31-386	.4375-20UNF	R1107W	R107D	U
RJ908SB10 and RDJ908SB10	RCDC38-453	RCADC38-453	.5000-20UNF	R1108W	R108D	29/64
RJ909SB11 and RDJ909SB11	RCDC47-569	RCADC47-569	.6250-18UNF	R1110W	R109D	9/16
RJ910SB12 and RDJ910SB12	RCDC56-687	RCADC56-687	.7500-16UNF	R1111W	R110D	11/16
RJ911SB14 and RDJ911SB14	RCDC64-802	RCADC64-802	.8750-14UNF	R1112W	R111D	25/32
RJ912SB16 and RDJ912SB16	RCDC72-927	RCADC72-927	1.0000-14UNS	R1113W	R112D	57/64
RJ913SB18 and RDJ913SB18	RCDC82-1043	RCADC82-1043	1.1250-12UNF	R1114W2	R113D	1 1/32
RJ914SB20	RCDC90-1165	RCADC90-1165	1.2500-12UNF	R1115W	R114D	1 11/64
RJ915SB22	RCDC100-1289	RCADC100-1289	1.3750-12UNF	R1116W	R115D	1 9/32

NOTES: UNLESS OTHERWISE SPECIFIED

- [1] Step drills are designed for thru hole drilling. When used to drill a blind hole, it may be necessary to grind the drill to suit the depth required.
- [2] Taps are not supplied by Rosan. For specific thread information refer to hole preparation on page 16.
- [3] Removal drills are not supplied by Rosan.
- 4. For tooling dimensional data refer to pages 45 thru 54.

**TOOLING,
INSERT - RING LOCKED**

**RJ900() AND RDJ900()
SERIES**

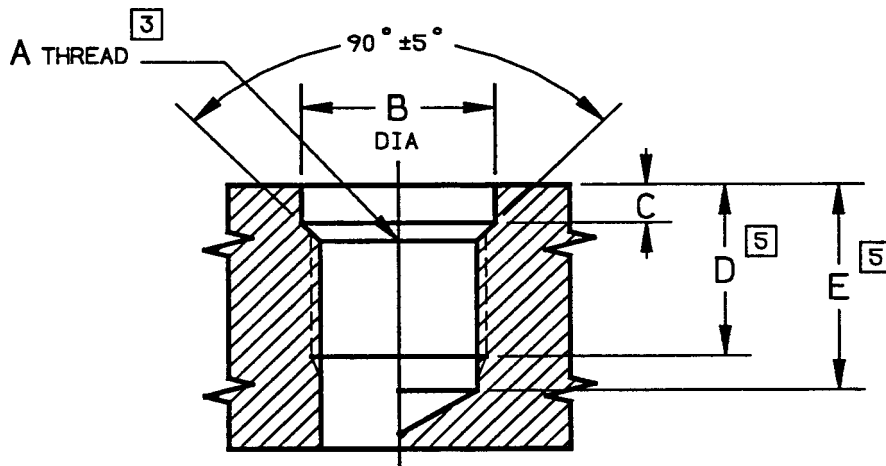

INSERT PART NUMBER REF	A THREAD CLASS 3B [3]	B DIA +.003 -.000 [1]		C +.030 -.000	D MIN FULL THREAD DEPTH [5]	E MIN DRILL DEPTH [5]	
		AL	MAG			PLUG TAP	BOTTOM TAP
		RJ902SB4 and RDJ902SB4	.1900-32UNJF			.250	.258
RJ903SB5 and RDJ903SB5	.2160-28UNJF	.281	.291	.109	.345	.506	.434
RJ904SB6 and RDJ904SB6	.2500-28UNJF	.328	.337	.109	.415	.576	.504
RJ905SB7 and RDJ905SB7	.3125-24UNJF	.375	.381	.141	.475	.663	.579
RJ906SB8 and RDJ906SB8	.3750-24UNJF	.437	.448	.156	.535	.723	.639
RJ907SB9 and RDJ907SB9	.4375-20UNJF	.484	.495	.172	.595	.820	.720
RJ908SB10 and RDJ908SB10	.5000-20UNJF	.593	.601	.172	.655	.880	.780
RJ909SB11 and RDJ909SB11	.6250-18UNJF	.734	.747	.188	.725	.975	.864
RJ910SB12 and RDJ910SB12	.7500-16UNJF	.875	.888	.203	.785	1.066	.941
RJ911SB14 and RDJ911SB14	.8750-14UNJF	1.000	.1015	.203	.915	1.236	1.094
RJ912SB16 and RDJ912SB16	1.0000-14UNJS	1.125	1.139	.203	1.035	1.356	1.214
RJ913SB18 and RDJ913SB18	1.1250-12UNJF	1.281	1.298	.219	1.155	1.530	1.363
RJ914SB20	1.2500-12UNJF	1.406	1.427	.219	1.285	1.660	1.493
RJ915SB22	1.3750-12UNJF	1.562	1.579	.219	1.415	1.790	1.623

NOTES: UNLESS OTHERWISE SPECIFIED

- [1] "B" diameter and minor diameter of thread to be concentric within .003 FIM.
- 2. When parent material surface is not flat or normal to axis of hole, provide a spotface for proper locking entry.
- [3] Thread as shown per MIL-S-8879 is preferred. Alternate thread per MIL-S-7742 class 3B or National class 3 is applicable when specified by design activity.
- 4. Remove all burrs and sharp edges.
- [5] "D" minimum full thread depth and "E" minimum drill depth are applicable for standard insert length shown only. For non standard lengths (see part number coding) "D" and "E" must change accordingly.

**HOLE PREPARATION,
INSERT - RING LOCKED**

**RJ900() AND RDJ900()
SERIES**

RJ100() SERIES

INSERT PART NUMBER	LOCKRING PART NUMBER	OVERSIZE INSERT [1] PART NUMBER	LOCKRING PART NUMBER
RJ102SB4	RLRR16SB5	RJ127SB4	RLRR18SB6
RJ103SB5	RLRR18SB6	RJ128SB5	RLRR21SB6
RJ104SB6	RLRR21SB6	RJ129SB6	RLRR24SB7
RJ105SB7	RLRR24SB7	RJ130SB7	RLRR28SB8
RJ106SB8	RLRR28SB8	RJ131SB8	RLRR31SB9
RAJ107SB9	RLRR33SB9	RJ157SB9	RLRR38SB9
RJ108SB10	RLRR38SB9	RJ133SB10	RLRR47SB10
RJ109SB11	RLRR47SB10	RJ134SB11	RLRR56SB11
RJ110SB12	RLRR56SB11	RJ135SB12	RLRR64SB11

RJ200() SERIES

INSERT PART NUMBER	LOCKRING PART NUMBER	OVERSIZE INSERT [1] PART NUMBER	LOCKRING PART NUMBER
RJ202SB4	RLRR16SB5	RJ227SB4	RLRR18SB6
RJ203SB5	RLRR18SB6	RJ228SB5	RLRR21SB6
RJ204SB6	RLRR21SB6	RJ229SB6	RLRR24SB7
RJ205SB7	RLRR24SB7	RJ230SB7	RLRR28SB8
RJ206SB8	RLRR28SB8	RJ231SB8	RLRR31SB9
RAJ207SB9	RLRR33SB9	RJ257SB9	RLRR38SB9
RJ208SB10	RLRR38SB9	RJ233SB10	RLRR47SB10
RJ209SB11	RLRR47SB10	RJ234SB11	RLRR56SB11
RJ210SB12	RLRR56SB11	RJ235SB12	RLRR64SB11

RJ300() SERIES

INSERT PART NUMBER	LOCKRING PART NUMBER	OVERSIZE INSERT [1] PART NUMBER	LOCKRING PART NUMBER
RJ302SB4	RLRR16SB5	RJ327SB4	RLRR18SB6
RJ303SB5	RLRR18SB6	RJ328SB5	RLRR21SB6
RJ304SB6	RLRR21SB6	RJ329SB6	RLRR24SB7
RJ305SB7	RLRR24SB7	RJ330SB7	RLRR28SB8
RJ306SB8	RLRR28SB8	RJ331SB8	RLRR31SB9
RJ307SB9	RLRR31SB9	RJ332SB9	RLRR38SB9
RJ308SB10	RLRR38SB9	RJ333SB10	RLRR47SB10
RJ309SB11	RLRR47SB10	RJ334SB11	RLRR56SB11
RJ310SB12	RLRR56SB11	RJ335SB12	RLRR64SB11
RJ311SB14	RLRR64SB11	RJ336SB14	RLRR72SB11
RJ312SB16	RLRR72SB11	RJ337SB16	RLRR82SB12
RJ312SB16F	RLRR72SB11	RJ337SB16	RLRR82SB12
RJ313SB18	RLRR82SB12	RJ338SB18	RLRR90SB12
RJ314SB20	RLRR90SB12	RJ339SB20	RLRR100SB12

RJ900() SERIES

INSERT PART NUMBER	LOCKRING PART NUMBER	OVERSIZE INSERT [1] PART NUMBER	LOCKRING PART NUMBER
RJ902SB4	RLRR16SB5	RJ927SB4	RLRR18SB6
RJ903SB5	RLRR18SB6	RJ928SB5	RLRR21SB6
RJ904SB6	RLRR21SB6	RJ929SB6	RLRR24SB7
RJ905SB7	RLRR24SB7	RJ930SB7	RLRR28SB8
RJ906SB8	RLRR28SB8	RJ931SB8	RLRR31SB???
RJ907SB9	RLRR31SB9	RJ932SB9	RLRR38SB9
RJ908SB10	RLRR38SB9	RJ933SB10	RLRR47SB10
RJ909SB11	RLRR47SB10	RJ934SB11	RLRR56SB11
RJ910SB12	RLRR56SB11	RJ935SB12	RLRR64SB11
RJ911SB14	RLRR64SB11	RJ936SB14	RLRR72SB11
RJ12SB16	RLRR72SB11	RJ937SB16	RLRR82SB12
RJ913SB18	RLRR82SB12	RJ938SB18	RLRR90SB12
RJ914SB20	RLRR90SB12	RJ939SB20	RLRR100SB12

NOTES: UNLESS OTHERWISE SPECIFIED

- 1** These inserts can be used to replace standard inserts in situations where the parent material thread has been damaged.
- 2.** For oversize insert hole preparation, installation and removal information, contact the Rosan Technical Sales Department.
- 3.** If the parent material counterbore diameter is damaged, an oversize lockring can be used for repair. Refer to page 40.

**OVERSIZE REPLACEMENT,
INSERT - RING LOCKED**

**RJ()
SERIES**

RJ100() SERIES

INSERT PART NUMBER	LOCKRING PART NUMBER	OVERSIZE INSERT [1] PART NUMBER	LOCKRING PART NUMBER
RDJ102SB4	RLRR16SB5	RDJ127SB4	RLRR18SB6
RDJ103SB5	RLRR18SB6	RDJ128SB5	RLRR21SB6
RDJ104SB6	RLRR21SB6	RDJ129SB6	RLRR24SB7
RDJ105SB7	RLRR24SB7	RDJ130SB7	RLRR28SB8
RDJ106SB8	RLRR28SB8	RDJ131SB8	RLRR31SB9
RADJ107SB9	RLRR33SB9	RDJ157SB9	RLRR38SB9
RDJ108SB10	RLRR38SB9	RDJ133SB10	RLRR47SB10
RDJ109SB11	RLRR47SB10	RDJ134SB11	RLRR56SB11
RDJ110SB12	RLRR56SB11	RDJ135SB12	RLRR64SB11

RJ200() SERIES

INSERT PART NUMBER	LOCKRING PART NUMBER	OVERSIZE INSERT [1] PART NUMBER	LOCKRING PART NUMBER
RDJ202SB4	RLRR16SB5	RDJ227SB4	RLRR18SB6
RDJ203SB5	RLRR18SB6	RDJ228SB5	RLRR21SB6
RDJ204SB6	RLRR21SB6	RDJ229SB6	RLRR24SB7
RDJ205SB7	RLRR24SB7	RDJ230SB7	RLRR28SB8
RDJ206SB8	RLRR28SB8	RDJ231SB8	RLRR31SB9
RADJ207SB9	RLRR33SB9	RDJ257SB9	RLRR38SB9
RDJ208SB10	RLRR38SB9	RDJ233SB10	RLRR47SB10
RDJ209SB11	RLRR47SB10	RDJ234SB11	RLRR56SB11
RDJ210SB12	RLRR56SB11	RDJ235SB12	RLRR64SB11

RJ300() SERIES

INSERT PART NUMBER	LOCKRING PART NUMBER	OVERSIZE INSERT [1] PART NUMBER	LOCKRING PART NUMBER
RDJ302SB4	RLRR16SB5	RDJ327SB4	RLRR18SB6
RDJ303SB5	RLRR18SB6	RDJ328SB5	RLRR21SB6
RDJ304SB6	RLRR21SB6	RDJ329SB6	RLRR24SB7
RDJ305SB7	RLRR24SB7	RDJ330SB7	RLRR28SB8
RDJ306SB8	RLRR28SB8	RDJ331SB8	RLRR31SB9
RDJ307SB9	RLRR31SB9	RDJ332SB9	RLRR38SB9
RDJ308SB10	RLRR38SB9	RDJ333SB10	RLRR47SB10
RDJ309SB11	RLRR47SB10	RDJ334SB11	RLRR56SB11
RDJ310SB12	RLRR56SB11	RDJ335SB12	RLRR64SB11
RDJ311SB14	RLRR64SB11	RDJ336SB14	RLRR72SB11
RDJ312SB16	RLRR72SB11	RDJ337SB16	RLRR82SB12
RDJ312SB16F	RLRR72SB11	RDJ337SB16	RLRR82SB12
RDJ313SB18	RLRR82SB12	RDJ338SB18	RLRR90SB12
RDJ314SB20	RLRR90SB12	RDJ339SB20	RLRR100SB12

RJ900() SERIES

INSERT PART NUMBER	LOCKRING PART NUMBER	OVERSIZE INSERT [1] PART NUMBER	LOCKRING PART NUMBER
RDJ902SB4	RLRR16SB5	RDJ927SB4	RLRR18SB6
RDJ903SB5	RLRR18SB6	RDJ928SB5	RLRR21SB6
RDJ904SB6	RLRR21SB6	RDJ929SB6	RLRR24SB7
RDJ905SB7	RLRR24SB7	RDJ930SB7	RLRR28SB8
RDJ906SB8	RLRR28SB8	RDJ931SB8	RLRR31SB9
RDJ907SB9	RLRR31SB9	RDJ932SB9	RLRR38SB9
RDJ908SB10	RLRR38SB9	RDJ933SB10	RLRR47SB10
RDJ909SB11	RLRR47SB10	RDJ934SB11	RLRR56SB11
RDJ910SB12	RLRR56SB11	RDJ935SB12	RLRR64SB11
RDJ911SB14	RLRR64SB11	RDJ936SB14	RLRR72SB11
RDJ12SB16	RLRR72SB11	RDJ937SB16	RLRR82SB12
RDJ913SB18	RLRR82SB12	RDJ938SB18	RLRR90SB12
RDJ914SB20	RLRR90SB12	RDJ939SB20	RLRR100SB12

NOTES: UNLESS OTHERWISE SPECIFIED

- 1 These inserts can be used to replace standard inserts in situations where the parent material thread has been damaged.
2. For oversize insert hole preparation, installation and removal information, contact the Rosan Technical Sales Department.
3. If the parent material counterbore diameter is damaged, an oversize lockring can be used for repair. Refer to page 40.

**OVERSIZE REPLACEMENT,
INSERT - RING LOCKED, WITH CBORE**

**RDJ ()
SERIES**

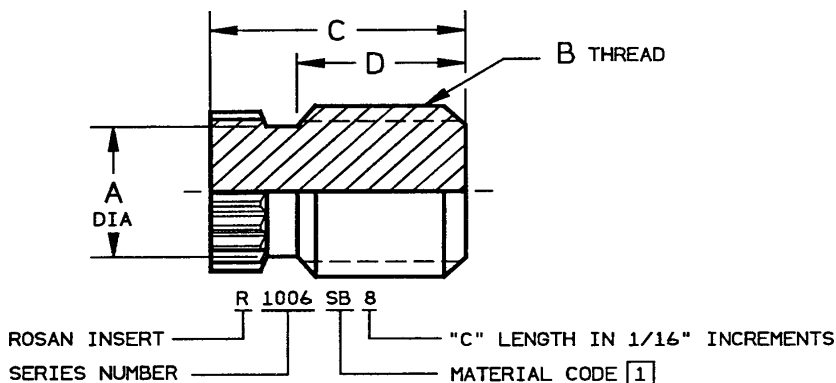

ROSAN INSERT PART NUMBER	LOCKRING		A DIA MIN	B EXTERNAL HEAD [4]			C ±.015	D ±.015
	ROSAN PART NUMBER [6] REF	MILITARY PART NUMBER [6][7] REF		SIZE	PITCH DIA	MINOR DIA		
R1002SB4	RLRR16SB5	MS51990-102P	.143	.1900-32	.1699-.1714	.1475-.1534	.250	.150
R1003SB5	RLRR18SB6	MS51990-103P	.170	.2160-28	.1931-.1946	.1674-.1740	.310	.190
R1004SB6	RLRR21SB6	MS51990-104P	.192	.2500-28	.2271-.2286	.2014-.2080	.380	.250
R1005SB7	RLRR24SB7	MS51990-104P	.243	.3125-24	.2858-.2873	.2559-.2632	.440	.290
R1006SB8	RLRR28SB8	MS51990-106P	.300	.3750-24	.3479-.3498	.3185-.3257	.500	.330
R1007SB9	RLRR31SB9	—————	.353	.4375-20	.4053-.4073	.3700-.3784	.560	.380
R1008SB10	RLRR38SB9	MS51990-108P	.442	.5000-20	.4678-.4698	.4325-.4409	.620	.420
R1009SB11	RLRR38SB9	MS51990-108P	.442	.5625-18	.5268-.5290	.4873-.4969	.690	.480
R1010SB12	RLRR47SB10	MS51990-109P	.548	.6250-18	.5894-.5914	.5498-.5593	.750	.520
R1011SB14	RLRR56SB11	MS51990-110P	.668	.7500-16	.7097-.7122	.6656-.6761	.880	.620
R1012SB16	RLRR64SB11	MS51990-111P	.763	.8750-14	.8291-.8316	.7786-.7904	1.000	.740
R1013SB18	RLRR72SB11	MS51990-112P	.877	1.0000-14	.9541-.9566	.9036-.9154	1.120	.870

NOTES: UNLESS OTHERWISE SPECIFIED

[1.] MATERIAL: 1117 steel per ASTM A108.

NOTE: These parts are available in other materials. Refer to page 27.

2. HEAT TREAT: None.

3. FINISH: Cadmium plate per QQ-P-416, TY II, CL3.

[4] The external thread has a special pitch diameter and minor diameter which installs into a MIL-S-8879 class 3B, MIL-S-7742 class 3B, or National class 3 tapped hole. Refer to page 55.

5. Inserts are installed and removed per page 28.

[6] Mating lockring is not included with insert. It must be ordered separately.

[7] For other MS51990 lockrings, see page 44.

**INSERT - RING LOCKED, SOLID
FINE EXTERNAL THREADS**

**R1000()
SERIES**

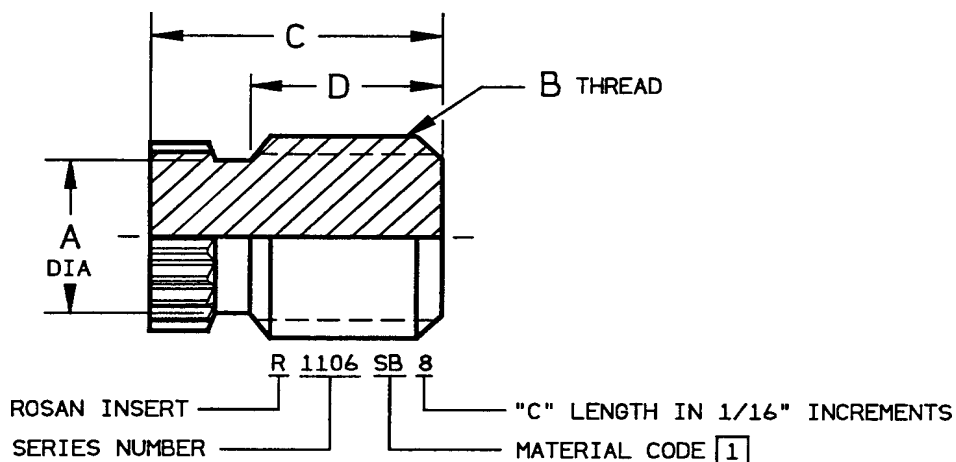

ROSAN INSERT PART NUMBER	LOCKRING		A DIA MIN	B EXTERNAL THREAD			C ±.015	D ±.015
	ROSAN PART NUMBER [6] REF	MILITARY PART NUMBER [6][7] REF		[4]				
	SIZE	PITCH DIA		MINOR DIA				
R1102SB4	RLRR16SB5	MS51990-102P	.143	.1900-24	.1633-.1648	.1334-.1407	.250	.150
R1103SB5	RLRR18SB6	MS51990-103P	.170	.2160-24	.1893-.1908	.1594-.1667	.310	.190
R1104SB6	RLRR21SB6	MS51990-104P	.192	.2500-20	.2178-.2198	.1824-.1909	.380	.250
R1105SB87	RLRR24SB7	MS51990-105P	.243	.3125-18	.2769-.2789	.2373-.2468	.440	.290
R1106SB8	RLRR28SB8	MS51990-106P	.300	.3750-16	.3347-.3372	.2906-.3011	.500	.330
R1107SB9	RLRR31SB9	—————	.353	.4375-14	.3916-.3941	.3411-.3529	.560	.380
R1108SB10	RLRR38SB9	MS51990-108P	.365	.5000-13	.4506-.4531	.3963-.4087	.620	.420
R1109SB11	RLRR38SB9	MS51990-108P	.440	.5625-12	.5091-.5116	.4503-.4635	.690	.480
R1110SB12	RLRR47SB10	MS51990-109P	.548	.6250-11	.5668-.5693	.5028-.5168	.750	.520
R1111SB14	RLRR56SB11	MS51990-110P	.607	.7500-10	.6860-.6885	.6156-.6308	.880	.620
R1112SB16	RLRR64SB11	MS51990-111P	.710	.8750-9	.8040-.8065	.7257-.7424	1.000	.740
R1113SB18	RLRR72SB11	MS51990-112P	.817	1.0000-8	.9202-.9227	.8322-.8505	1.120	.870

NOTES: UNLESS OTHERWISE SPECIFIED

[1] MATERIAL: 1117 steel per ASTM A 108.

NOTE: These parts are available in other materials. Refer to page 27.

2. HEAT TREAT: None.

3. FINISH: Cadmium plate per QQ-P-416, TYII, CL3.

[4] The external thread has a special pitch diameter and minor diameter which installs into a MIL-S-8879 class 3B, MIL-S-7742 class 3B, or National class 3 tapped hole. Refer to page 55.

5. Inserts are installed and removed per page 28.

[6] Mating lockring is not included with insert. It must be ordered separately.

[7] For other MS51990 lockrings, see page 44.

**INSERT - RING LOCKED, SOLID
COARSE EXTERNAL THREADS**

**R1100()
SERIES**



STEP DRILL



TAP



WRENCH



LOCKRING DRIVE TOOL

INSERT PART NUMBER	STEP DRILL PART NUMBER [1]		BASIC TAP SIZE [2]	WRENCH PART NUMBER	LOCKRING DRIVE TOOL PART NUMBER	REMOVAL DRILL SIZE [3]
	ALUMINIUM	MAGNESIUM				
R1002SB4	RCDC16-159	RCADC16-159	.1900-32UNF	R1102W	R1102D	7/32
R1102SB4	RCDC16-149	RCADC16-149	.1900-24UNC			
R1103SB5	RCDC18-180	RCADC18-180	.2160-28UNF	R1103W	R1103D	1/4
R1003SB5	RCDC18-177	RCADC18-177	.2160-24UNC			
R1004SB6	RCDC21-213	RCADC21-213	.2500-28UNF	R1104W	R1104D	19/64
R1104SB6	RCDC21-201	RCADC21-201	.2500-20UNC			
R1005SB7	RCDC24-272	RCADC24-272	.3125-24UNF	R1005W	R1005D	F
R1105SB7	RCDC24-257	RCADC24-257	.3125-18UNC			
R1006SB8	RCDC28-332	RCADC28-332	.3750-24UNF	R1106W	R1106D	5/16
R1106SB8	RCDC28-312	RCADC28-312	.3750-16UNC			
R1007SB9	RCDC31-386	RCADC31-386	.4375-20UNF	R1107W	R1107D	U
R1107SB9	RCDC31-368	RCADC31-368	.4375-14UNC			
R1008SB10	RCDC38-453	RCADC38-453	.5000-20UNF	R1108W	R1108D	29/64
R1108SB10	RCDC38-422	RCADC38-422	.5000-13UNC			
R1009SB11	RCDC38-506	RCADC38-506	.5625-18UNF	R1108W	R1108D	29/64
R1109SB11	RCDC38-484	RCADC38-484	.5625-12UNC			
R1010SB12	RCDC47-569	RCADC47-569	.6250-18UNF	R1110W	R1110D	9/16
R1110SB12	RCDC47-535	RCADC47-535	.6250-11UNC			
R1011SB14	RCDC56-687	RCADC56-687	.7500-16UNF	R1111W	R1111D	11/16
R1111SB14	RCDC56-656	RCADC56-656	.7500-10UNC			
R1012SB16	RCDC64-802	RCADC64-802	.8750-14UNF	R1112W	R1112D	25/32
R1112SB16	RCDC64-765	RCADC64-765	.8750-9UNC			
R1013SB18	RCDC72-927	RCADC72-927	1.0000-14UNS	R1113W	R1113D	57/64
R1113SB18	RCDC72-875	RCADC72-875	1.0000-8UNC			

NOTES: UNLESS OTHER SPECIFIED

[1] Step drills are designed for thru hole drilling. When used to drill a blind hole, it may be necessary to grind the drill to suit the depth required.

[2] Taps are not supplied by Rosan. For specific thread information refer to hole preparation on page 22.

[3] Removal drills are not supplied by Rosan.

4. For tooling dimensional data refer to pages 45 thru 54.

**TOOLING,
INSERT - RING LOCKED, SOLID**

**R1000() AND R1100()
SERIES**

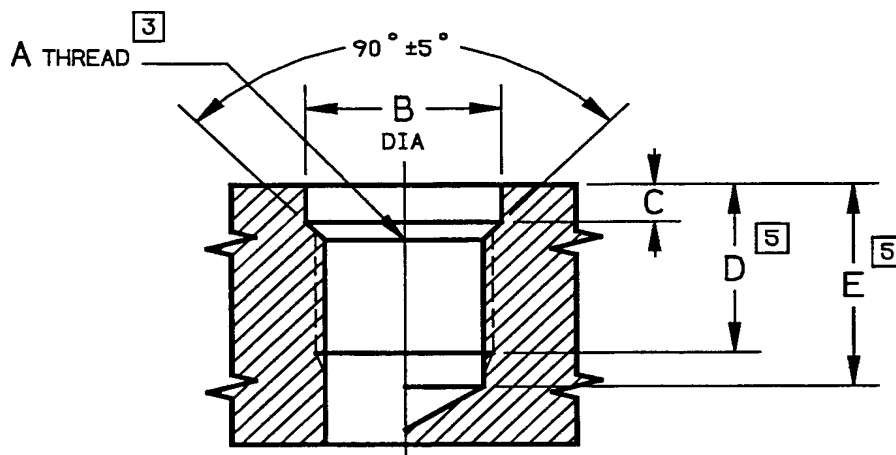

INSERT PART NUMBER REF	A THREAD CLASS 3B [3]	B DIA +.003 -.000 [1]		C +.030 -.000	D MIN FULL THREAD DEPTH [5]	E MIN DRILL DEPTH [5]	
		AL	MAG			PLUG TAP	BOTTOM TAP
		R1002SB4	.1900-32UNJF			.250	.258
R1102SB4	.1900-24UNJC					.472	.389
R1003SB5	.2160-28UNJF	.281	.291	.109	.345	.506	.434
R1103SB5	.2160-24UNJC					.532	.449
R1004SB6	.2500-28UNJF	.328	.337	.109	.415	.576	.504
R1104SB6	.2500-20UNJC					.640	.540
R1005SB7	.3125-24UNJF	.375	.381	.141	.475	.663	.579
R1105SB7	.3125-18UNJC					.725	.614
R.1006SB8	.3750-24UNJF	.437	.448	.156	.535	.723	.639
R1106SB8	.3750-16UNJC					.816	.691
R1007SB9	.4375-20UNJF	.484	.495	.172	.595	.820	.720
R1107SB9	.4375-14UNJC					.916	.774
R1008SB10	.5000-20UNJF	.593	.601	.172	.655	.880	.780
R1108SB10	.5000-13UNJC					1.001	.847
R1009SB11	.5625-18UNJF	.593	.601	.172	.725	.975	.864
R1109SB11	.5625-12UNJC					1.10	.933
R1010SB12	.6250-18UNJF	.734	.747	.188	.785	1.035	.924
R1110SB12	.6250-11UNJC			.218		1.194	1.012
R1011SB14	.7500-16UNJF	.875	.888	.203	.915	1.196	1.071
R1111SB14	.7500-10UNJC					1.365	1.165
R1012SB16	.8750-14UNJF	1.000	1.015	.203	1.035	1.356	1.214
R1112SB16	.8750-9UNJC					1.535	1.313
R1013SB18	1.0000-14UNJS	1.125	1.139	.203	1.155	1.476	1.334
R1113SB18	1.0000-8UNJC					1.718	1.468

NOTES: UNLESS OTHERWISE SPECIFIED

[1] "B" diameter and minor diameter of thread to be concentric within .003 FIM.

2. When parent material surface is not flat or normal to axis of hole, provide a spotface for proper locking entry.

[3] Thread as shown per MIL-S-8879 is preferred. Alternate thread per MIL-S-7742 class 3B or National class 3 is applicable when specified by design activity.

4. Remove all burrs and sharp edges.

[5] "D" minimum full thread depth and "E" minimum drill depth are applicable for standard insert length shown only. For non standard lengths (see part number coding) "D" and "E" must change accordingly.

**HOLE PREPARATION,
INSERT - RING LOCKED, SOLID**

**R1000() AND R1100()
SERIES**

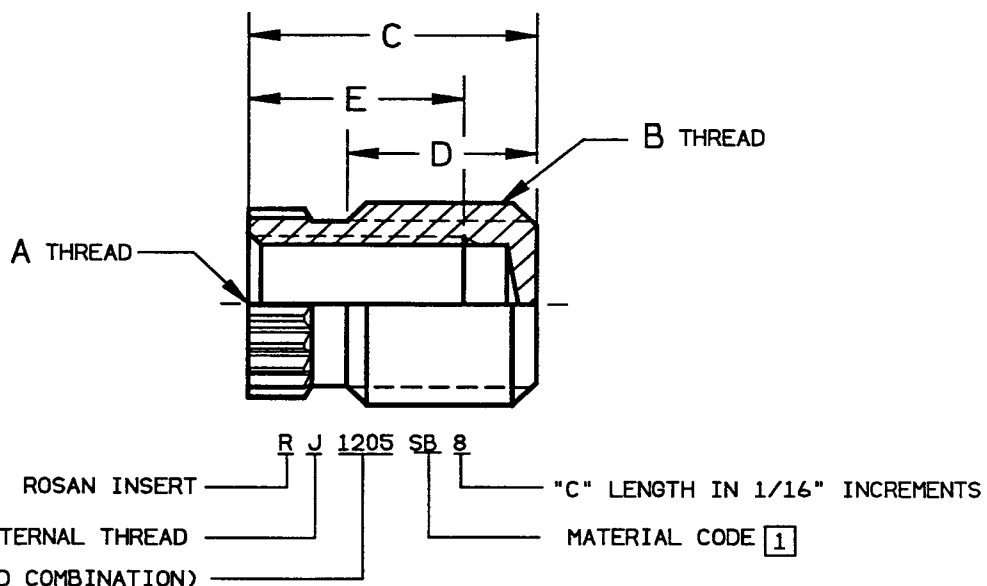

ROSAN INSERT PART NUMBER	LOCKRING		A INTERNAL THREAD CLASS-3B	B EXTERNAL THREAD [4]			C ±.015	D ±.015	E MINIMUM FULL THREAD DEPTH
	ROSAN PART NUMBER [6] REF	MILITARY PART NUMBER [6][7] REF		SIZE	PITCH DIA	MINOR DIA			
	RJ1202SB5	RLRR16SB5		MS51990-120P	.1120-48UNJF	.1900-24			
RJ1203SB6	RLRR18SB6	MS51990-103P	.1380-40UNJF	.2160-24	.1893-.1908	.1594-.1667	.380	.260	.19
RJ1204SB7	RLRR21SB6	MS51990-104P	.1640-36UNJF	.2500-20	.2178-.2198	.1824-.1909	.440	.310	.25
RJ1205SB8	RLRR24SB7	MS51990-105P	.1900-32UNJF	.3125-18	.2769-.2789	.2373-.2468	.500	.350	.28
RJ1206SB10	RLRR28SB8	MS51990-106P	.2500-28UNJF	.3750-16	.3347-.3372	.2906-.3011	.620	.450	.38
RAJ1207SB11	RLRR33SB9	MS51990-107P	.3125-24UNJF	.5000-13	.4506-.4531	.3963-.4087	.690	.490	.41
RJ1208SB13	RLRR38SB9	MS51990-108P	.3750-24UNJF	.5625-12	.5091-.5116	.4503-.4635	.810	.600	.53
RJ1209SB16	RLRR47SB10	MS51990-109P	.4375-20UNJF	.6250-11	.5668-.5693	.5028-.5168	1.000	.770	.66
RJ1210SB17	RLRR56SB11	MS51990-110P	.5000-20UNJF	.7500-10	.6860-.6885	.6156-.6308	1.060	.810	.72

NOTES: UNLESS OTHERWISE SPECIFIED.

[1] MATERIAL: 1117 steel per ASTM A108.

NOTE: These parts are available in other materials. Refer to page 27.

2. HEAT TREAT: None.

3. FINISH: Cadmium plate per QQ-P-416, TY II, CL3.

[4] The external thread has a special pitch diameter and minor diameter which installs into a MIL-S-8879 class 3B, MIL-S-7742 class 3B, or National class 3 tapped hole. Refer to page 55.

5. Inserts are installed and removed per page 28.

[6] Mating lockring is not included with insert. It must be ordered separately.

[7] For other MS51990 lockrings, see page 44.

**INSERT - RING LOCKED, BLIND
FINE INTERNAL AND COARSE EXTERNAL THREADS**

**RJ1200()
SERIES**

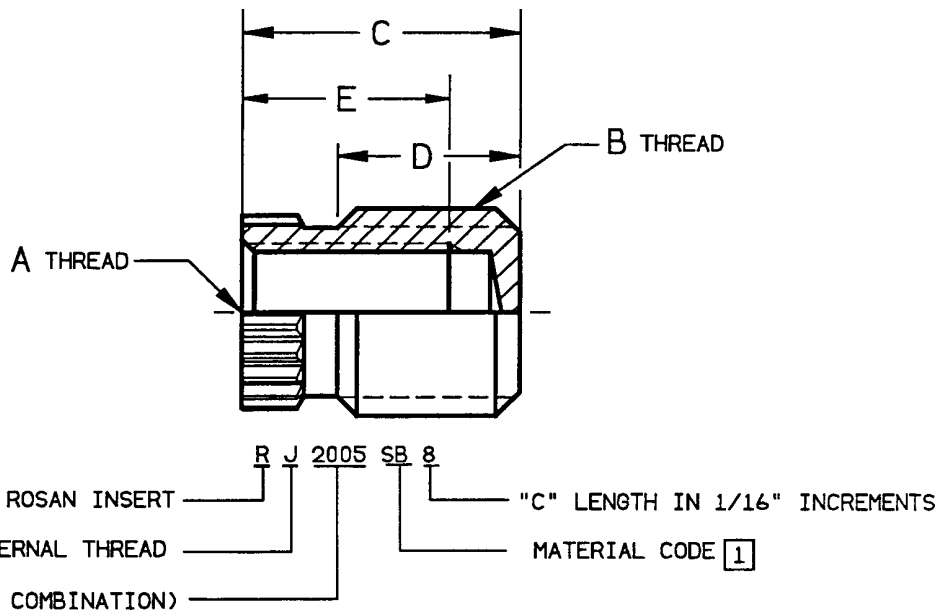

ROSAN INSERT PART NUMBER	LOCKRING		A INTERNAL THREAD CLASS-3B	B EXTERNAL THREAD [4]			C ±.015	D ±.015	E MINIMUM FULL THREAD DEPTH
	LOCKRING PART NUMBER [6] REF	MILITARY PART NUMBER [6][7] REF		SIZE	PITCH DIA	MINOR DIA			
	RJ2002SB5	RLRR16SB5		MS51990-102P	.1120-40UNJC	.1900-24			
RJ2003SB6	RLRR18SB6	MS51990-103P	.1380-32UNJC	.2160-24	.1893-.1908	.1594-.1667	.380	.260	.16
RJ2004SB7	RLRR21SB6	MS1990-104P	.1640-32UNJC	.2500-20	.2178-.2198	.1824-.1909	.440	.310	.22
RJ2005SB8	RLRR24SB7	MS51990-105P	.1900-24UNJC	.3125-18	.2769-.2789	.2373-.2468	.500	.350	.25
RJ2006SB10	RLRR28SB8	MS51990-106P	.2500-20UNJC	.3750-16	.3347-.3372	.2906-.3011	.620	.450	.31
RAJ2007SB11	RLRR33SB9	MS51990-107P	.3125-18UNJC	.5000-13	.4506-.4531	.3963-.4087	.690	.490	.38
RJ2008SB13	RLRR38SB9	MS51990-108P	.3750-16UNJC	.5625-12	.5091-.5116	.4503-.4635	.810	.600	.44
RJ2009SB16	RLRR47SB10	MS51990-109P	.4375-14UNJC	.6250-11	.5668-.5693	.5028-.5168	1.000	.770	.50
RJ2010SB17	RLRR56SB11	MS51990-110P	.5000-13UNJC	.7500-10	.6860-.6885	.6156-.6308	1.060	.810	.62

NOTES: UNLESS OTHERWISE SPECIFIED

[1] MATERIAL: 1117 steel per ASTM A108.

NOTE: These parts are available in other materials. Refer to page 27.

2. HEAT TREAT: None.

3. FINISH: Cadmium plate per QQ-P-416, TY II, CL3.

[4] The external thread has a special pitch diameter and minor diameter which installs into a MIL-S-8879 class 3B, MIL-S-7742 class 3B, or National class 3 tapped hole. Refer to page 55.

5. Inserts are installed and removed per page 28.

[6] Mating lockring is not included with insert. It must be ordered separately.

[7] For other MS51990 lockrings, see page 44.

**INSERT - RING LOCKED, BLIND
COARSE INTERNAL AND COARSE EXTERNAL THREADS**

**RJ2000()
SERIES**



STEP DRILL



TAP



WRENCH



LOCKRING DRIVE TOOL

INSERT PART NUMBER REF	STEP DRILL PART NUMBER [1]		BASIC TAP SIZE [2] REF	WRENCH PART NUMBER	LOCKRING DRIVE TOOL PART NUMBER	REMOVAL DRILL SIZE [3] REF
	ALUMINUM	MAGNESIUM				
RJ1202SB5 RJ2002SB5	RCDC16-149-5	RCADC16-149-5	.1900-24UNC	R1102W	R102D	7/32
RJ1203SB6 RJ2003SB6	RCDC18-177-6	RCADC18-177-6	.2160-24UNC	R1103W	R103D	1/4
RJ1204SB7 RJ2004SB7	RCDC21-201S	RCADC21-201S	.2500-20UNC	R1104W	R104D	19/64
RJ1205SB8 RJ2005SB8	RCDC24-257S	RCADC24-257S	.3125-18UNC	R1105W	R205D R105D	F
RJ1206SB10 RJ2006SB10	RCDC28-312S	RCADC28-312S	.3750-16UNC	R1106W	R206D R106D	5/16
RAJ1207SB11 RAJ2007SB11	RCDC33-422-11	RCADC33-422-11	.5000-13UNC	R1107XW	RA207D RA107D	V
RJ1208SB13 RJ2008SB13	RCDC38-484-13	RCADC38-484-13	.5625-12UNC	R1108W	R208D R108D	29/64
RJ1209SB16 RJ2009SB16	RCDC47-535	RCADC47-535	.6250-11UNC	R1110W	R209D R109D	9/16
RJ1210SB17 RJ2010SB17	RCDC56-656	RCADC56-656	.7500-10UNC	R1111W	R210D R110D	11/16

NOTES: UNLESS OTHERWISE SPECIFIED

[1] Step drills are designed for thru hole drilling. When used to drill a blind hole, it may be necessary to grind the drill to suit the depth required.

[2] Taps are not supplied by Rosan. For specific thread information refer to hole preparation on page 26.

[3] Removal drills are not supplied by Rosan.

4. For tooling dimensional data refer to pages 45 thru 54.

**TOOLING, RJ1200() AND RJ2000()
INSERT RING LOCKED, BLIND SERIES**

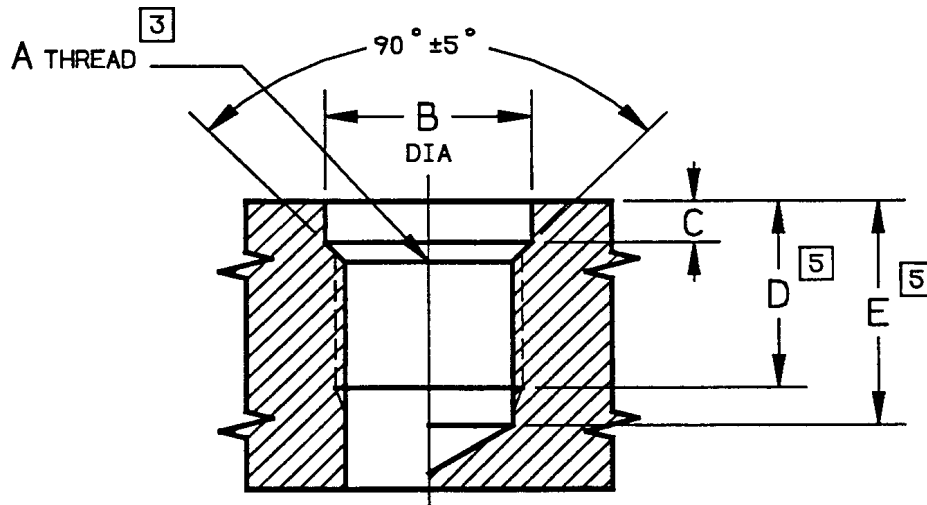

INSERT PART NUMBER REF	A THREAD CLASS 3B [3]	B DIA +.003 -.000 [1]		C +.030 -.000	D MIN FULL THREAD DEPTH [5]	E MIN DRILL DEPTH [5]	
		AL	MAG			PLUG TAP	BOTTOM TAP
		RJ1202SB5 and RJ2002SB5	.1900-24UNJC			.250	.258
RJ1203SB6 and RJ2003SB6	.2160-24UNJC	.281	.291	.109	.415	.602	.519
RJ1204SB7 and RJ2004SB7	.2500-20UNJC	.328	.337	.109	.475	.700	.600
RJ1205SB8 and RJ2005SB8	.3125-18UNJC	.375	.381	.141	.535	.785	.674
RJ1206SB10 and RJ2006SB10	.3750-16UNJC	.437	.448	.156	.655	.936	.811
RAJ1207SB11 and RAJ2007SB11	.5000-13UNJC	.515	.526	.172	.725	1.071	.917
RJ1208SB13 and RJ2008SB13	.5625-12UNJC	.593	.601	.172	.845	1.220	1.053
RJ1209SB16 and RJ2009SB16	.6250-11UNJC	.734	.747	.218	1.035	1.444	1.262
RJ1210SB17 and RJ2010SB17	.7500-10UNJC	.875	.888	.203	1.095	1.545	1.345

NOTES: UNLESS OTHERWISE SPECIFIED

- 1 "B" diameter and minor diameter of thread to be concentric within .003 FIM.
2. When parent material surface is not flat or normal to axis of hole, provide a spotface for proper locking entry.
- 3 Thread as shown per MIL-S-8879 is preferred. Alternate thread per MIL-S-7742 class 3B or National class 3 is applicable when specified by design activity.
4. Remove all burrs and sharp edges.
- 5 "D" minimum full thread depth and "E" minimum drill depth are applicable for standard insert lengths shown only. For non standard lengths (see part number coding) "D" and "E" must change accordingly.

**HOLE PREPARATION RJ1200() AND RJ2000()
INSERT RING LOCKED, BLIND SERIES**

INSERT					
CODE	MATERIAL	SPECIFICATION	HEAT TREAT	FINISH WITHOUT INTERNAL THREAD	FINISH WITH INTERNAL THREAD
SA [1]	4130 STEEL	MIL-S-6758, COND F	125KSI UTS MIN	CAD PLATE PER QQ-P-416, TYII, CL3	CAD PLATE PER QQ-P-416, TYII, CL3
SB [1]	1117 STEEL	ASTM A108	NONE		
SF	17-4PH CRES	AMS5643	COND H1025	PASSIVATE QQ-P-35	PASSIVATE PER QQ-P-35 PLUS SOLID FILM LUBE
SM [1]	303 CRES	ASTM A581 OR ASTM A582	NONE		
SN	4340 STEEL ALTERNATE: 4140 STEEL	MIL-S-5000	160-180 KSI UTS	CAD PLATE PER QQ-P-416, TY II, CL3	CAD PLATE PER QQ-P-416, TY II, CL3
		MIL-S-5625			
SU [1]	A286 CRES	AMS5731 OR AMS5734	83HRB MIN [6] [2]	PASSIVATE PER QQ-P-35	PASSIVATE PER QQ-P-35 PLUS SOLID FILM LUBE
TA	6Al-4V TITANIUM	MIL-T-9047 COND A	130 KSI UTS MIN	NONE	[3]

LOCKRING				
CODE	MATERIAL	SPECIFICATION	HEAT TREAT	FINISH
SA	4130 STEEL	MIL-S-6758, COND F	125 KSI UTS MIN	CAD PLTE PER QQ-P-416, YII, CL3
SB [1]	1117 STEEL	ASTM A108	CASE HARDEN 36-45 HRC [4]	
SM [1]	303SE CRES	ASTM A581 OR ASTM A582	NONE	PASSIVATE QQ-P-35
SU [1]	A286 CURES	AMS5731 OR AMS5734	269 HB MIN	PASSIVATE PER QQ-P-35
S3C [5]	718 CRES	AMS5662	230 KSI UTS MIN	PASSIVATE PER QQ-P-3

NOTES: UNLESS OTHERWISE SPECIFIED:

- [1] Noted codes indicate standard materials.
- [2] For A286 heat treated to 130 KSI UTS min, add suffix EO349 to insert part number.
- [3] Internal thread locking feature not available at this time.
- [4] For 1117 Steel case hardened to 50-60 HRC, add suffix EO238 to lockring part number.
- [5] Refer to the RLH(S3C) series lockring on page 43.
- [6] RJ1700 Series Inserts are heat treated to 130 KSI UTS min and Note [2] does not apply.

**MATERIALS AND FINISHES,
INSERT AND LOCKRING**

**R(), RJ(),
RDJ() & RLRR()
SERIES**

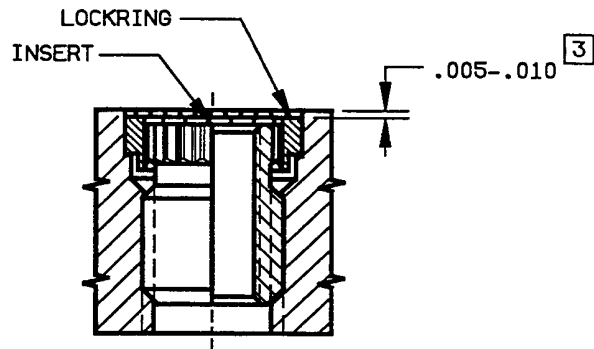
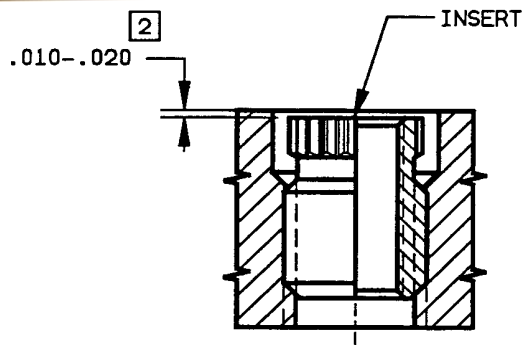

INSTALLATION

1. Parent material must be prepared per applicable insert hole preparation sheet or in accordance with MS51994.
- [2] Using applicable wrench, install insert to depth shown.
- [3] Using applicable lockring drive tool, drive lockring into parent material until drive tool bottoms against the top of parent material surface. This will set lockring to proper depth.

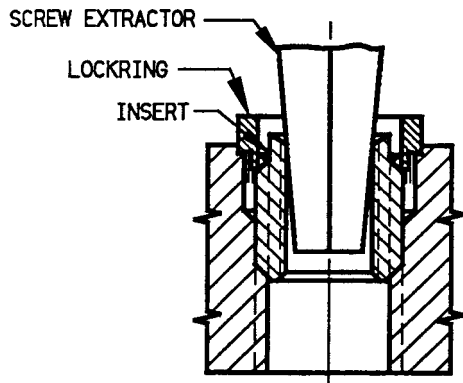
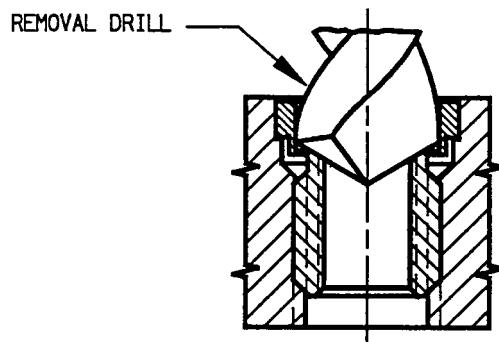

REMOVAL

1. Securely clamp part from which insert is to be removed to drill press table. Align drill spindle with hole in insert.
2. Secure removal drill in chuck and set spindle speed at 300 at 700 RPM.
3. Drill through lockring into the neck of insert to destroy serration interlock. Do not drill beyond the depth of the counterbore in the parent material.
NOTE: Solid inserts, R1000 and R1100 series must be drilled to accept a screw extractor before destroying the serration interlock.
4. When removing hydraulic ring locked inserts, drill only thru serrated flange of insert. Do not drill thru second flange. See page 30 for removal drill depth.
5. Drive square screw extractor into insert and apply removal torque. When insert thread flanks bear against lower surface of lockring, continued removal torque will cause the lockring to be jacked out. Insert removal may thus be completed.
6. If lockring has been drilled completely through and fails to lift out with insert, the remaining portion may be collapsed with a punch and removed.

NOTE:

Replacement of Rosan insert and lockring is made with same size components as those removed and is installed in the same manner as original installation. Rotate new lockring if necessary, before driving, to a position in which the external serrations are aligned with those in the parent material.

INSTALLATION AND REMOVAL, R(), RJ() AND RDJ() INSERT - RING LOCKED SERIES

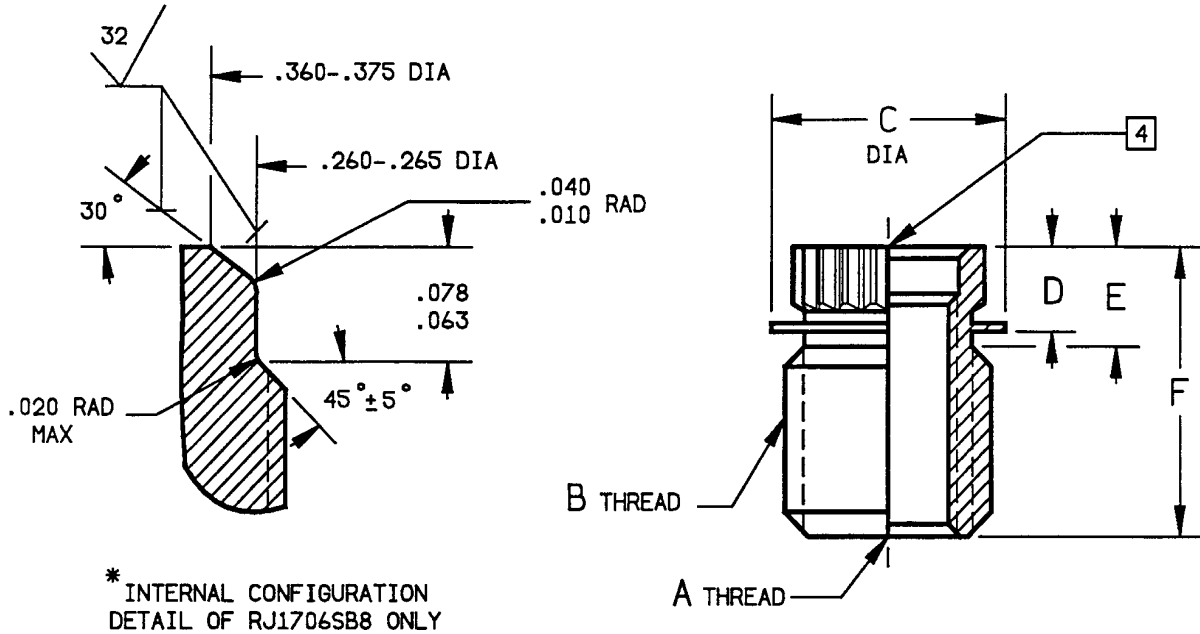

INSERT PART NUMBER [7]	LOCKRING PART NUMBER [8] REF	A INTERNAL THREAD CLASS-3B	B EXTERNAL THREAD CLASS-3A	C DIA ±.005	D ±.005	E ±.005	F ±.015
* RJ1706SB8	RL33SB7	.2500-28UNJF	.4375-20 UNF	.510	.176	.276	.500
RJ1707SB8	RL38SB7	.3125-24UNJF	.5000-20UNF	.588	.176	.276	.500
RJ1708SB8	RL47SB8	.3750-24UNJF	.6250-18UNF	.729	.191	.302	.500
RJ1709SB9	RL47SB8	.4375-20UNJF	.6250-18UNF	.729	.191	.302	.560
RJ1710SB9	RL56SB8	.5000-20UNJF	.7500-16UNF	.870	.191	.316	.560
RJ1711SB9	RL56SB8	.5625-18UNJF	.7500-16UNF	.870	.191	.316	.560
RJ1713SB10	RL72SB8	.7500-16UNJF	1.0000-14UNF	1.120	.191	.334	.620

NOTES: UNLESS OTHERWISE SPECIFIED

1. MATERIAL: 1117 steel per ASTM A108.

NOTE: These parts are available in other materials. Refer to page 27.

2. FINISH: Cadmium plate per QQ-P-416, TY II, CL3.

3. Inserts are installed per page 31.

[4] Internal configuration meets the requirements of MS33649 except RJ1706SB8.

5. Refer to RF9500 Series Catalog for 3000 PSI External Sealing Configuration.

6. Properly installed with designer's choice of packing ring these fasteners will effect an external seal of 150 PSI. For O-ring information refer to page 31.

[7] RJ1700 Series supersedes R1700 Series due to AND10050 being superseded by MS33649.

[8] The hydraulic insert is used in conjunction with a thin series lockring. Refer to page 41 and 42.

INSERT - RING LOCKED, HYDRAULIC (150 PSI)

**RJ1700()
SERIES**

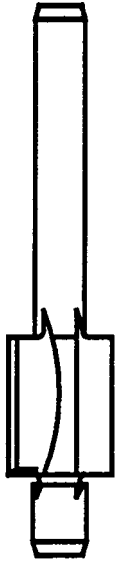

COUNTERBORE
TOOL



TAP



WRENCH



LOCKRING DRIVE TOOL

INSERT PAR NUMBER	COUNTERBORE TOOL PART NUMBER	BASIC TAP SIZE [1] REF	WRENCH PART NUMBER	LOCKRING DRIVE TOOL PART NUMBER	REMOVAL DRILL SIZE [2] EF	DEPTH TO USE REMOVAL DRILL
RJ1706SB8	RC33-386	.4375-20UNF	R1107XW	R1706D	27/64	.140
RJ1707SB8	RC38-453	.5000-20UNF	R1108W	R1707D	31/64	.140
RJ1708SB8	RC47-569	.6250-18UNF	R1110W	R1708D	19/32	.156
RJ1709SB9	RC47-569	.6250-18UNF	R1110W	R209D	19/32	.156
RJ1710SB9	RC56-687	.7500-16UNF	R1111W	R210D	23/32	.156
RJ1711SB9	RC56-687	.7500-16UNF	R1111W	R1711D	23/32	.156
RJ1713SB10	RC72-927	1.0000-14UNS	R1113W	R1713D	15/16	.15

NOTES: UNLESS OTHERWISE SPECIFIED

[1] Taps are not supplied by Rosan. For specific thread information refer to hole preparation on page 31.

[2] Removal drills are not supplied by Rosan.

3. For tooling dimensional data refer to pages 45 thru 54.

**TOOLING,
INSERT - RING LOCKED
HYDRAULIC (150 PSI)**

**RJ1700()
SERIES**

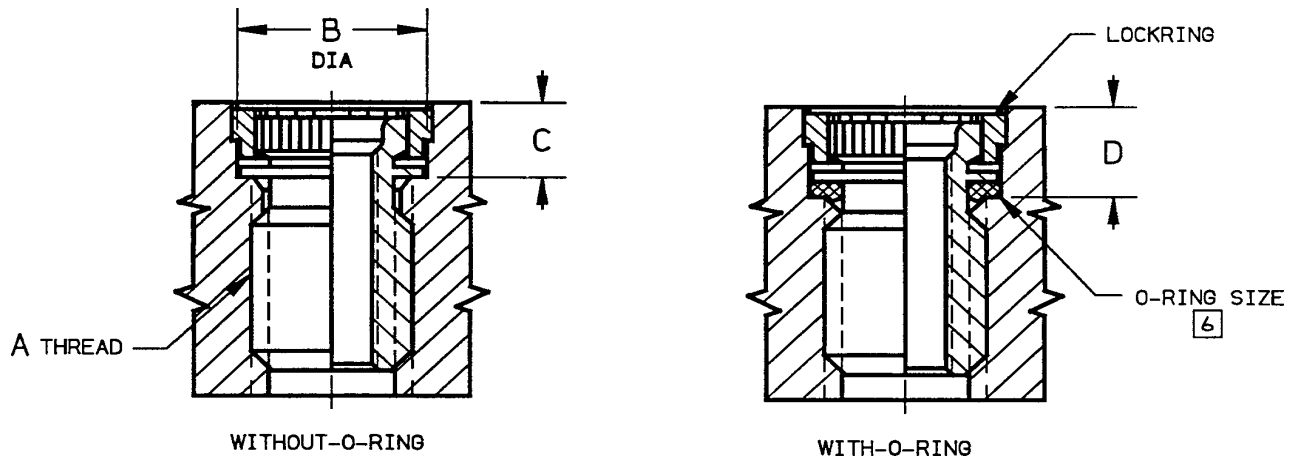

INSERT PART NUMBER	A THREAD CLASS 3B [2]	B DIA +.003 -.000 [1]	C C BORE [3] DEPTH	D C BORE [4] DEPTH	TAP DRILL SIZE REF	O-RING SIZE [6] REF
RJ1706SB8	.4375-20UNJF	.515	.186	.226	386	AS568-012
RJ1707SB8	.5000-20UNJF	.593	.186	.229	.453	AS568-110
RJ1708SB9	.6250-18UNJF	.734	.201	.284	.569	AS568-112
RJ1709SB9	.6250-18UNJF	.734	.201	.284	.569	AS568-112
RJ1710SB9	.7500-16UNJF	.875	.201	.284	.687	AS568-115
RJ1711SB9	.7500-16UNJF	.875	.201	.284	.687	AS568-115
RJ173SB10	1.0000-14UNJF	1.125	.201	.330	.927	AS568-212

NOTES: UNLESS OTHERWISE SPECIFIED

- [1] "B" diameter and minor diameter of thread to be concentric within .003 FIM.
- [2] Thread as shown per MIL-S-8879 is preferred. Alternate thread per MIL-S-7742 class 3B or National class 3 is applicable when specified by design activity.
- [3] WITHOUT O-RING: Use for dust and foreign matter exclusion. Install part until flange is seated in c' bore. Do not use excessive wrench torque.
- [4] WITH O-RING: Use to effect fluid seal for pressures up to 150 PSI. See note 6. Install part until top serrated flange is .010 to .020 below surface.
- 5. Drive lockring from .005 to .010 below material surface.
- [6] O-rings must be specified separately and shall be selected based on system fluid and temperature and are not supplied by Rosan. Dash numbers shown in the table conform to SAE standard (AS568) uniform dash numbering system. With proper installation and proper choice of o-ring, fluid seal up to 150 PSI will be effected.
- [7] For removal procedure see page 28. Install new insert per paragraphs 3 thru 6 above.

**HOLE PREPARATION AND INSTALLATION,
INSERT - RING LOCKED
HYDDRAULIC (150 PSI)**

**RJ1700()
SERIES**

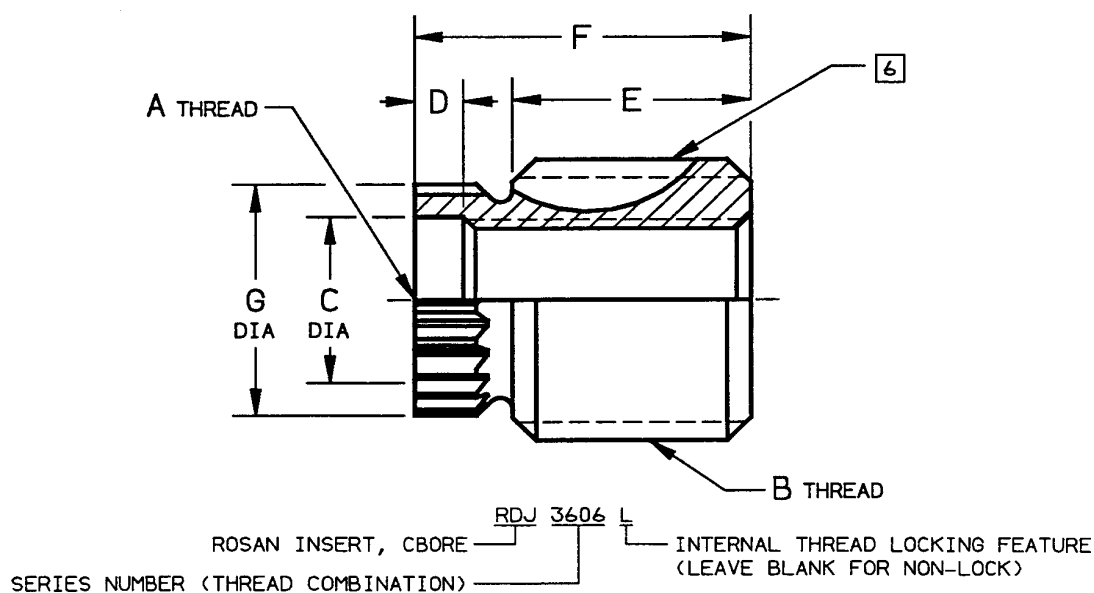

INSERT PART NUMBER	LOCKRING PART NUMBER	A INTERNAL THREAD UNJF-3B MIL-S-8879	B EXTERNAL THREAD [4]			C DIA ±.005	D ±.005	E ±.015	F ±.015	G DIA ±.005
			SIZE	PITCH DIA	MINOR DIA					
RDJ3604L	RL21SB4	.1640-32	.3125-18	.2769-.2789	.2373-.2468	.170	.075	.200	.280	.232
RDJ3605L	RL24SB5	.1900-32	.3750-16	.3347-.3372	.2906-.3011	.196	.075	.210	.310	.286
RDJ3606L	RL28SB5	.2500-28	.4375-14	.3916-.3941	.3411-.3529	.257	.083	.270	.380	.347
RDJ3607L	RL33SB6	.3125-24	.5000-13	.4506-.4531	.3963-.4087	.320	.097	.350	.470	.410
RDJ3608L	RL38SB7	.3750-24	.5625-12	.5091-.5116	.4873-.4998	.382	.097	.480	.620	.490
RDJ3609L	RL43SB7	.4375-20	.6250-11	.5668-.5693	.5498-.5603	.445	.113	.610	.750	.542

NOTES: UNLESS OTHERWISE SPECIFIED

1. MATERIAL: 4140 Steel or equivalent.
2. HEAT TREAT: 160 - 180 UTS.
3. FINISH: Cadmium plate per QQ-P-416, TY II, CL3. plus carbon-wax lubricant on parts with internal thread lock.
- [4] The external thread has a special pitch diameter and minor diameter which installs into a MIL-S-8879 class 3B, MIL-S-7742 class 3B, or National class 3 tapped hole. Refer to page 55.
5. Inserts are installed and removed per page 28.
- [6] Internal thread locking feature complies with applicable portion of specification MIL-N-25027 for 450°F.

INSERT - RING LOCKED, HIGH STRENGTH

**RDJ3600()
 SERIES**



STEP DRILL



TAP



WRENCH



LOCKRING DRIVE TOOL

INSERT PART NUMBER REF	STEP DRILL PART NUMBER [1]	BASIC TAP SIZE [2] REF	WRENCH PART NUMBER	LOCKRING DRIVE TOOL PART NUMBER	REMOVAL DRILL SIZE [3] REF
RDJ3604L	RCDC21-257	.3125-18UNC	R1104W	R3604D	#6
RDJ3605L	RCDC24-312	.3750-16UNC	R1105W	R3605D	F
RDJ3606L	RCDC28-368	.4375-14UNC	R1106W	R3606D	5/16
RDJ3607L	RCDC33-422	.5000-13UNC	R1107XW	R3607D	V
RDJ3608L	RCDC38-516	.5625-12UNC	R1108W	R3608D	29/64
RDJ3609L	RCDC43-578	.6250-11UNC	R1109W	R3609D	1/2

NOTES: UNLESS OTHERWISE SPECIFIED

[1] Step drills are designed for thru hole drilling. When used to drill a blind hole, it may be necessary to grind the drill to suit the depth required.

[2] Taps are not supplied by Rosan. For specific thread information refer to hole preparation on page 34.

[3] Removal drills are not supplied by Rosan.

4. For tooling dimensional data refer to pages 45 thru 54.

**TOOLING,
INSERT - RING LOCKED, HIGH STRENGTH**

**RDJ3600()
SERIES**

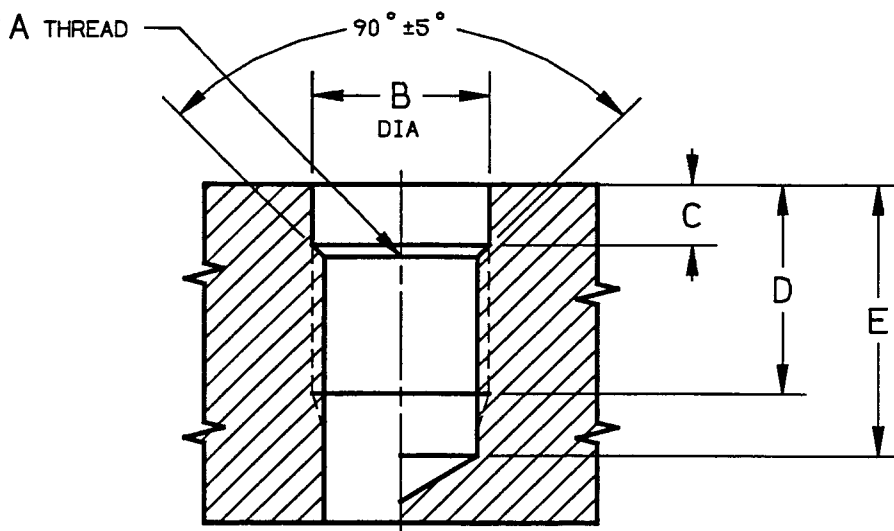

INSERT PART NUMBER REF	HOLE PREPARATION						DESIGN DATA				
	A THREAD CLASS 3B [2]	B DIA [1] ±.003 -.000	C	D MIN FULL THREAD DEPTH	E MIN DRILL DEPTH		TAP DRILL SIZE	INSERT PULL OUT STRENGTH MIN (lbf)		BOLT STRENGTH F _{tu} (lbf)	
					PLUG TAP	BOTTOM TAP		356-T6	2024-T4	145,000	180,000
RDJ3604L	.3125-18UNC	.328	.078	.315	.565	.454	F	3,100	4,300	2,030	2,550
RDJ3605L	.3750-16UNC	.375	.109	.345	.626	.501	5/16	3,620	4,700	2,900	3,600
RDJ3606L	.4375-14UNC	.437	.109	.415	.736	.594	U	5,170	8,900	5,278	6,500
RDJ3607L	.5000-13UNC	.515	.125	.505	.851	.697	27/64	7,800	12,600	8,410	10,440
RDJ3608L	.5625-12UNC4	.593	.141	.655	1.030	.863	33/64	13,100	17,500	12,730	15,800
RDJ3609L	.6250-11UNC4	.671	.141	1.194	1.012	1.012	37/64	17,700	27,000	17,210	21,360

NOTES: UNLESS OTHERWISE SPECIFIED

- [1] "B" diameter and minor diameter of thread to be concentric within .003 FIM.
- [2] Thread as shown per MIL-S-8879 is preferred. Alternate thread per MIL-S-7742 class 3B or National class 3 is applicable when specified by design activity.
- 3. RD 3600 Series inserts are designed for maximum loads in tension within the minimum envelope dimensions. The design data table lists test pull-out strengths developed by the inserts when installed in 356-T6 and 2024-T4 aluminum alloys with ultimate shear strengths of 25,000 and 37,000 PSI respectively. The calculated ultimate strengths of bolt heat-treated to 145,000 PSI and 180,000 PSI are listed for reference and are based on tensile stress areas listed in FED-STD-H28.
- [4] Modified minor dia due to tap drill.

**HOLE PREPARATION AND DESIGN DATA,
INSERT - RING LOCKED, HIGH STRENGTH**

**RDJ3600()
SERIES**

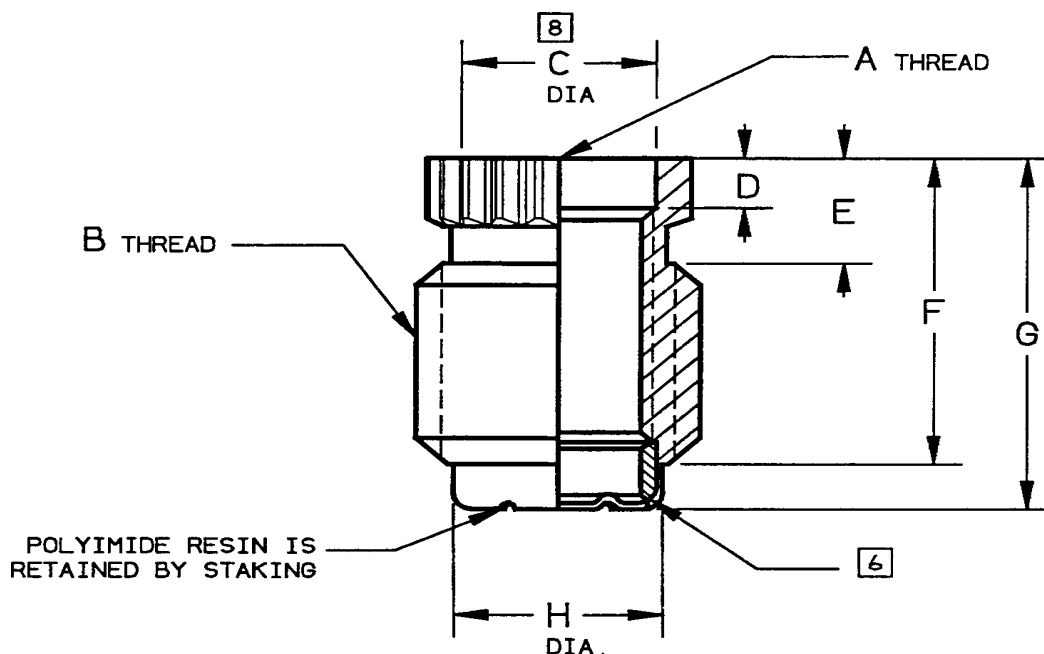

INSERT PART NUMBER	LOCKRING PART NUMBER [7] REF	A INTERNAL THREAD UNJF-3B	B EXTERNAL THREAD [4]			C DIA ±.007 -.002	D ±.005	E ±.010	F ±.010	G ±.015	H DIA MAX
			SIZE	PITCH DIA	MINOR DIA						
05-13008-050	RL24SU5	.1900-32	.3750-24	.3479-.3498	.3185-.3257	.196	.075	.105	.390	.456	.297
05-13008-060	RL28SU5	.2500-28	.4375-20	.4056-.4073	.3700-.3784	.257	.083	.105	.504	.602	.360
05-13008-070	RL-33SU6	.3125-24	.5000-20	.4678-.4698	.4325-.4409	.320	.097	.120	.640	.775	.417

NOTES: UNLESS OTHERWISE SPECIFIED

1. MATERIAL: A286 per AMS 5731 OR 5734.

2. HEAT TREAT: Brinell 269 min.

3. FINISH: Solid film lubricant per requirements of MIL-L-46010 (Tiolube).

Note: Overspray is permissible on internal thread locking feature.

[4.] The external thread has a special pitch diameter and minor diameter which installs into a MIL-S-8879 class 3B, MIL-S-7742 class 3B, or National class 3 tapped hole.

Refer to page 55. Thread dimensions are prior to the addition of solid film lube.

5. Inserts are installed and removed per page 28.

[6.] Polyimide Resin (SP-1) Type internal thread locking feature.

[7.] Mating Lockring is not included with insert. It must be ordered separately.

[8.] Thread marks permissible inside counterbore.

**INSERT - RING LOCKED
POLYIMIDE RESIN LOCK**

**05-13008()
SERIES**

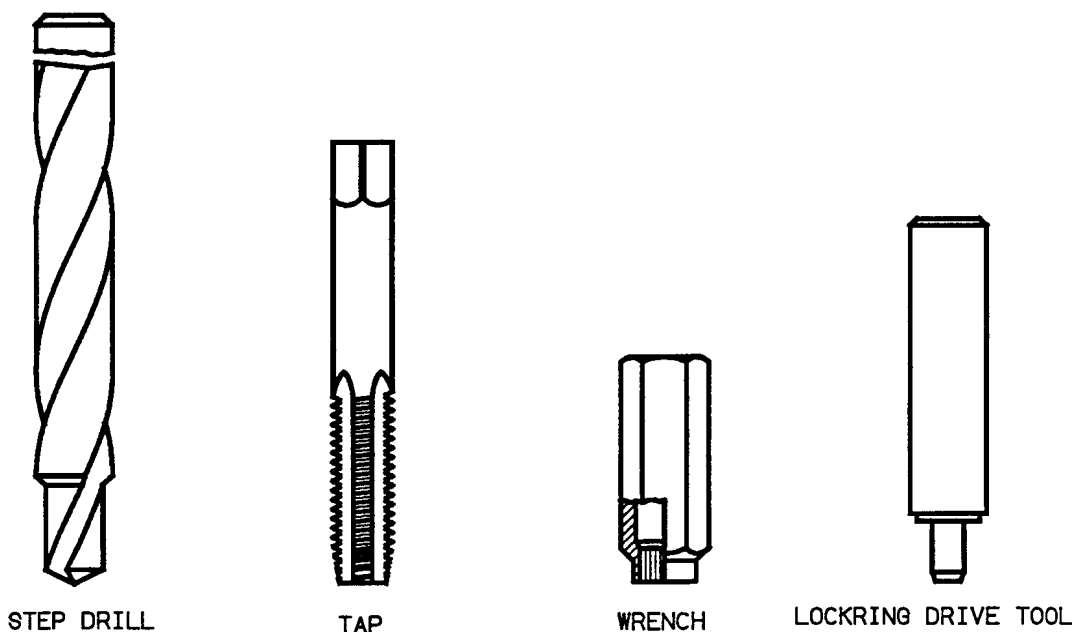

INSERT PART NUMBER REF	STEP DRILL PART NUMBER [1]	BASIC TAP SIZE [2] REF	WRENCH PART NUMBER	LOCKRING DRIVE TOOL PART NUMBER	REMOVAL DRILL SIZE [3] REF
05-13008-050	RCDC24-332	.3750-24UNC	R1105W	R3605D	F
05-13008-060	RCDC28-386	.4370-20UNC	R1106W	R3606D	5/16
05-13008-070	RCDC33-453	.5000-20UNC	R1107XW	R3607D	V

NOTES: UNLESS OTHERWISE SPECIFIED

- [1] Step drills are designed for thru hole drilling. When used to drill a blind hole, it may be necessary to grind the drill to suit the depth required.
- [2] Taps are not supplied by Rosan. For specific thread information refer to hole preparation on page 37.
- [3] Removal drills are not supplied by Rosan. Tap drill for blind tapping to be as required to provide bolt clearance. The bolt is to pass thru the polyimide resin lock of the insert a minimum of two pitches including chamfer.
- 4. For tooling dimensional data refer to pages 45 thru 54.

**TOOLING,
INSERT - RING LOCKED
POLYIMIDE RESIN LOCK**

**05-13008()
SERIES**

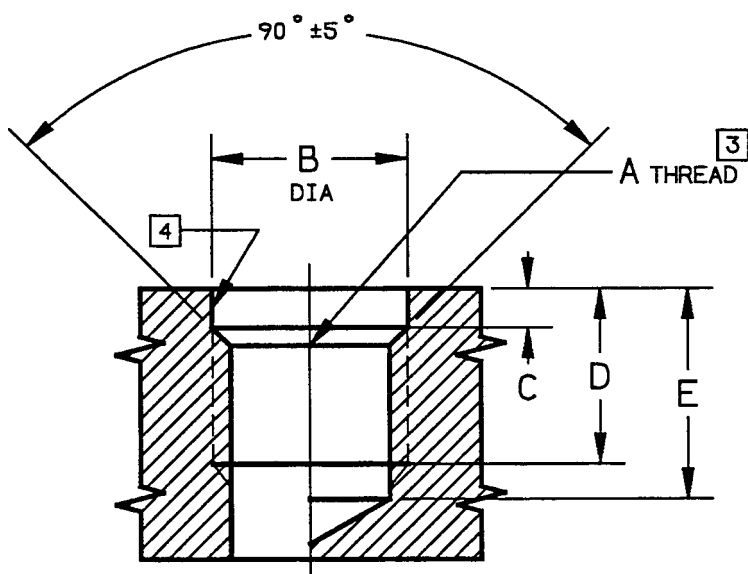

INSERT PART NUMBER	HOLE PREPARATION					
	A	B	C	D	E	
	THREAD CLASS 3B [3]	DIA [1] ±.005 -.000	 ±.015 -.000	MIN FULL THREAD DEPTH	MIN DRILL DEPTH [5]	PLUG TAP
05-13008-050	.3750-24UNJF	.375	.109	.410	.597	.514
05-13008-060	.4375-20UNJF	.437	.109	.524	.749	.666
05-13008-070	.5000-20UNJF	.515	.125	.660	.885	.850

NOTES: UNLESS OTHERWISE SPECIFIED

- [1] "B" diameter and minor diameter of thread to be concentric within .003 FIM.
2. When parent material surface is not flat or normal to axis of hole, provide a spotface for proper locking entry.
- [3] Thread as shown per MIL-S-8879 is preferred. Alternate thread per MIL-S-7742 class 3B or National class 3 is applicable when specified by design activity..
- [4] Thread marks permissible inside counterbore.
- [5] Dimensions are based on bolt protrusion of two pitches through insert locking device. It does not include required stack up tolerances.

**HOLE PREPARATION,
INSERT - RING LOCKED
POLYIMIDE RESIN LOCK**

**05-13008 ()
SERIES**

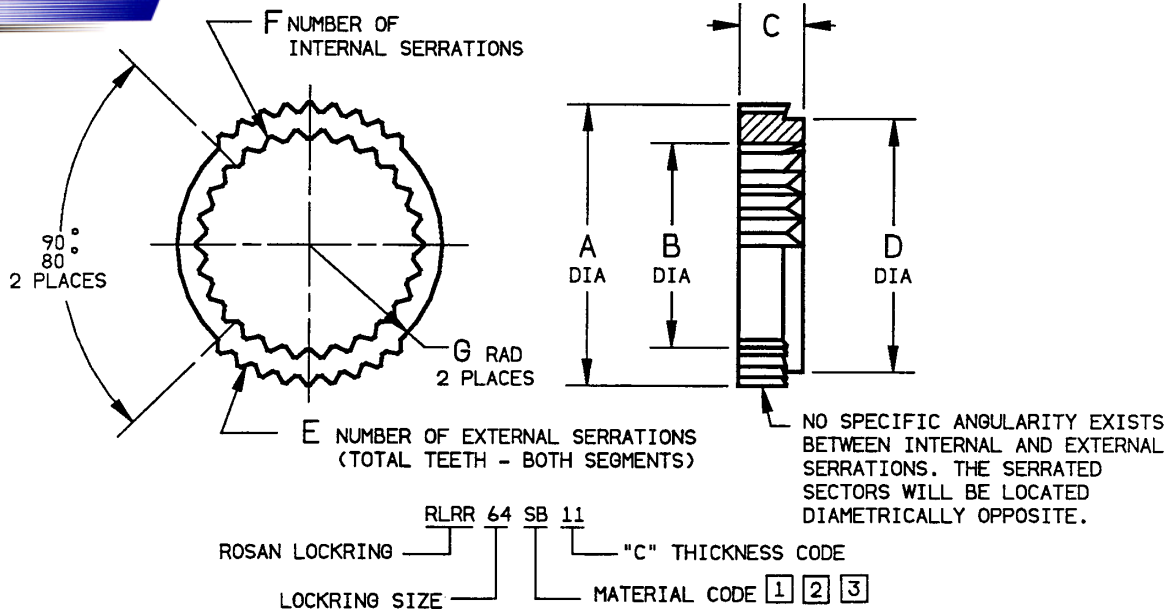

LOCKRING				A	B	C	D	E	F	G
ROSAN PART NUMBER	MILITARY PART NUMBER	ROSAN PART NUMBER	MILITARY PART NUMBER	DIA	DIA		DIA	REF		RAD
	REF		REF	+0.005 -0.004	+0.004 -0.003	±0.005	±0.005			±0.005
RLRR16SB5	MS51990-102P	RLRR16SU5	MS51990E102P	.274	.161	.084	.223	10	14	.120
RLRR18SB6	MS51990-103P	RLRR18SU6	MS51990E103P	.308	.189	.099	.255	10	16	.135
RLRR21SB6	MS51990-104P	RLRR21SU6	MS51990E104P	.354	.213	.099	.298	12	13	.159
RLRR24SB7	MS51990-105P	RLRR24SU7	MS51990E105P	.399	.266	.112	.343	12	17	.180
RLRR28SB8	MS51990-106P	RLRR28SU8	MS51990E106P	.468	.323	.138	.400	14	20	.214
RLRR31SB9	—	RLRR31SU9	—	.514	.375	.145	.452	16	23	.236
RLRR33SB9	MS51990-107P	RLRR33SU9	MS51990E107P	.545	.390	.145	.480	18	24	.252
RLRR38SB9	MS51990-108P	RLRR38SU9	MS51990E108P	.624	.468	.145	.560	20	26	.293
RLRR47SB10	MS51990-109P	RLRR47SU10	MS51990E109P	.767	.574	.161	.702	22	26	.362
RLRR56SB11	MS51990-110P	RLRR56SU11	MS51990E110P	.910	.695	.176	.837	24	30	.431
RLRR64SB11	MS51990-111P	RLRR64SU11	MS51990E111P	1.040	.795	.176	.958	20	30	.492
RLRR72SB11	MS51990-112P	RLRR72SU11	MS51990E112P	1.170	.908	.176	1.078	22	38	.551
RLRR82SB12	MS51990-113P	RLRR82SU12	MS51990E113P	1.326	1.035	.193	1.232	20	36	.636
RLRR90SB12	MS51990-114P	RLRR90SU12	MS51990E114P	1.456	1.189	.193	1.371	20	48	.692
RLRR100SB12	MS51990-115P	RLRR100SU12	MS51990E115P	1.611	1.282	.193	1.509	16	42	.770

NOTES: UNLESS OTHERWISE SPECIFIED

[1] MATERIAL: SB-1117 Steel per ASTM A108.

SU - A286 Cres per AMS5731 or AMS5734.

NOTE: These lockrings are available in other materials.
Refer to page 27.

[2] FINISH: SB - Cadmium plate per QQ-P-416, Type II, CL 3.

SU - Passivate per QQ-P-35.

[3] HARDNESS: SB - Case hardened to 36-45 HRC.

SU - Hardened to 269 HB min.

LOCKRING - MS51990-() TYPE

**RLRR()
SERIES**

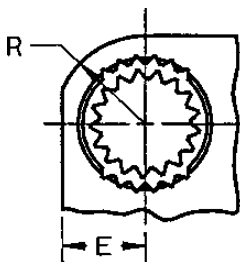

ROSAN PART NUMBER REF	MILITARY PART NUMBER	ROSAN PART NUMBER REF	MILITARY PART NUMBER	CBORE DIA ±.003 -.000		R MIN	E MIN
				AL	MAG		
RLRR16SB5	MS51990-102P	RLRR16SU5	MS51990E102P	.250	.258	.17	.155
RLRR18SB6	MS51990-103P	RLRR18SU6	MS51990E103P	.281	.291	.20	.175
RLRR21SB6	MS51990-104P	RLRR21SU6	MS51990E104P	.328	.337	.22	.200
RLRR24SB7	MS51990-105P	RLRR24SU7	MS51990E105P	.375	.381	.25	.230
RLRR28SB8	MS51990-106P	RLRR28SU8	MS51990E106P	.437	.448	.31	.270
RLRR31SB9	—	RLRR31SU9	—	.484	.495	.34	.300
RLRR33SB9	MS51990-107P	RLRR33SU9	MS51990E107P	.515	.526	.36	.320
RLRR38SB9	MS51990-108P	RLRR38SU9	MS51990E108P	.593	.601	.42	.365
RLRR47SB10	MS51990-109P	RLRR47SU10	MS51990E109P	.734	.747	.50	.450
RLRR56SB11	MS51990-110P	RLRR56SU11	MS51990E110P	.875	.888	.62	.535
RLRR64SB11	MS51990-111P	RLRR64SU11	MS51990E111P	1.000	1.015	.69	.605
RLRR72SB11	MS51990-112P	RLRR72SU11	MS51990E112P	1.125	1.139	.75	.675
RLRR82SB12	MS51990-113P	RLRR82SU12	MS51990E113P	1.281	1.298	.89	.765
RLRR90SB12	MS51990-114P	RLRR90SU12	MS51990E114P	1.406	1.427	.95	.830
RLRR100SB12	MS51990-115P	RLRR100SU12	MS51990E115P	1.562	1.579	1.06	.915

NOTES: UNLESS OTHERWISE SPECIFIED

- The minimum boss ("R" and "E") shown in the above table are the minimum dimensions applicable for lockring installation into either aluminum or magnesium parent material.

**TYPICAL TORQUE OUT TESTS
6061-T6 ALUMINUM (27,000 PSI SHEAR)**

LOCKRING PART NUMBER	CBORE DIA	INSTALLATION FORCE (lbf)	TEST TORQUE (lbf-in)	TEST RESULTS *	REQUIREMENTS (lbf-in)	
					INSERT	STUD
RLRR16()5	.250-.261	375-750	70-75	1	20	30
RLRR18()6	.281-.284	975-1150	90-110	1	30	45
	.291-.294	450-510	60-80	2	30	45
RLRR()6	.328-.331	1100-1490	200-220	1	45	65
	.337-.340	550-690	110-50	2	45	65
RLRR24()7	.375-.384	870-1820	230-295	2	65	150
RLRR28()8	.437-.451	700-2100	390-490	2	150	300
RLRR33()9	.515-.529	900-2300	550-804	2	300	550

* 1 Stud Sheared - 2 Lockrings Turned

**DESIGN DATA,
LOCKRING - MS51990-() TYPE**

**RLRR()
SERIES**

E NUMBER OF EXTERNAL SERRATIONS (TOTAL TEETH - BOTH SEGMENTS)

F NUMBER OF INTERNAL SERRATIONS

90°
80°
2 PLACES

G
2 PLACES

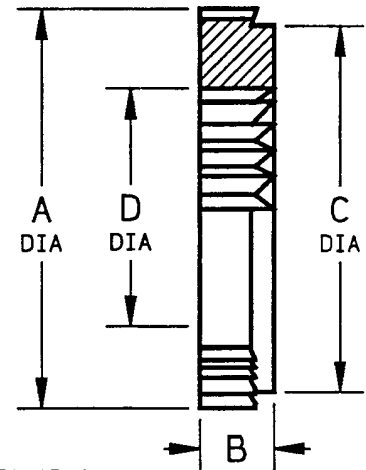

NO SPECIFIC ANGULARITY EXISTS BETWEEN INTERNAL AND EXTERNAL SERRATIONS THE SERRATED SECTORS WILL BE LOCATED DIAMETRICALLY OPPOSITE

ROSAN LOCKRING — RLRR 47 38 SB 9

EXTERNAL SERRATION SIZE —

INTERNAL SERRATION SIZE —

"B" THICKNESS CODE

MATERIAL CODE [1] [2] [3]

LOCKRING PART NUMBER		A DIA	B	C DIA	D DIA	E REF	F	G RAD
(1117) (MATERIAL)	(A286) (MATERIAL)	+0.005 -0.004	±.005	±.005	+0.004 -0.003			±.005
RLRR1816SB5	RLRR1816SU5	.308	.084	.255	.161	10	14	.135
RLRR2118SB6	RLRR2118SU6	.354	.099	.298	.189	12	16	.159
RLRR2421SB6	RLRR2421SU6	.399	.099	.343	.213	12	13	.180
RLRR2824SB7	RLRR2824SU7	.468	.112	.400	.266	14	17	.214
RLRR3128SB8	RLRR3128SU8	.514	.138	.452	.323	16	20	.236
RLRR3331SB9	RLRR3331SU9	.545	.145	.480	.375	18	23	.252
RLRR3833SB9	RLRR3833SU9	.624	.145	.560	.390	20	24	.293
RLRR4738SB9	RLRR4738SU9	.767	.145	.702	.468	22	26	.362
RLRR5647SB10	RLRR5647SU10	.910	.161	.837	.574	24	26	.431
RLRR6456SB11	RLRR6456SU11	1.040	.176	.958	.695	20	30	.492
RLRR7264SB11	RLRR7264SU11	1.170	.176	1.078	.795	22	30	.551
RLRR8272SB11	RLRR8272SU11	1.326	.176	1.232	.908	20	38	.636
RLRR9082SB12	RLRR9082SU12	1.456	.193	1.371	1.035	20	36	.692
RLRR10090SB12	RLRR10090SU12	1.611	.193	1.509	1.189	16	48	.770
RLRR124100SB12	RLRR124100SU12	1.987	.193	1.885	1.282	22	42	.957

NOTES: UNLESS OTHERWISE SPECIFIED

[1] MATERIAL: SB - 1117 steel per ASTM 108.

SU - A286 Cres per AMS5731 or AMS5734.

NOTE: These lockrings are available in other materials. Refer to page 27.

[2] FINISH: SB - Cadmium plate per QQ-P-416, Type II, CL3.

SU - Passivate per QQ-P-35.

[3] HARDNESS: SB - Case hardened to 36—45 HRC

SU - Hardened to 269 HB min.

LOCKRING - OVERSIZE REPLACEMENT

**RLRR()
SERIES**

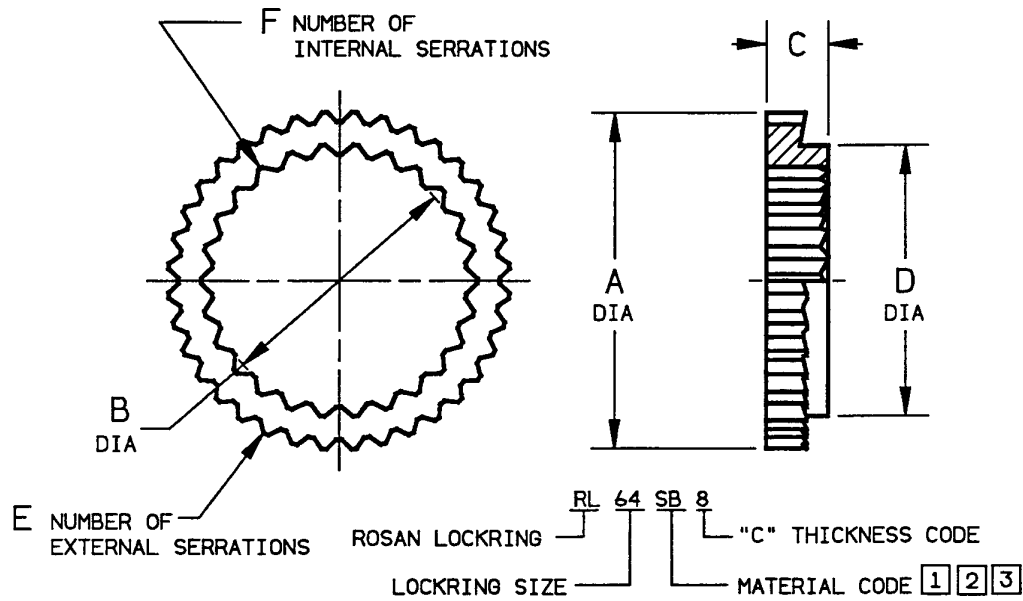

LOCKRING PART NUMBER		A DIA	B DIA	C	D DIA	E	F
(117) MATERIAL	(A286) MATERIAL	±.005	±.005	±.005	±.005		
RL21SB4	RL21SU4	.354	.213	.068	.298	24	13
RL24SB5	RL24SU5	.399	.266	.081	.343	24	17
RL28SB5	RL28SU5	.468	.323	.081	.400	26	20
RL28SB6	RL28SU6	.468	.323	.099	.400	26	20
RL31SB6	RL31SU6	.514	.375	.099	.452	30	23
RL33SB6	RL33SU6	.545	.390	.099	.480	34	24
RL33SB7	RL33SU7	.545	.390	.115	.480	34	24
RL38SB7	RL38SU7	.624	.468	.115	.560	36	26
RL43SB7	RL43SU7	.699	.520	.115	.636	36	26
RL47SB8	RL47SU8	.767	.574	.130	.702	40	26
RL56SB8	RL56SU8	.910	.695	.130	.837	44	30
RL64SB8	RL64SU8	1.040	.795	.138	.958	38	30
RL72SB8	RL72SU8	1.170	.908	.130	1.078	40	38

NOTES: UNLESS OTHERWISE SPECIFIED

[1] MATERIAL: SB-1117 Steel per ASTM A108.

SU - A286 Cres per AMS5731 or AMS5734.

NOTE: These parts are available in other materials. Refer to page 27.

[2] FINISH: SB - Cadmium plate per QQ-P-416, Type II, CL 3.

SU - Passivate per QQ-P-35.

[3] HARDNESS: SB - Case hardened to 36-45 HRC.

SU - Hardened to 269 HB min.

LOCKRING - THIN

**RL()
SERIES**

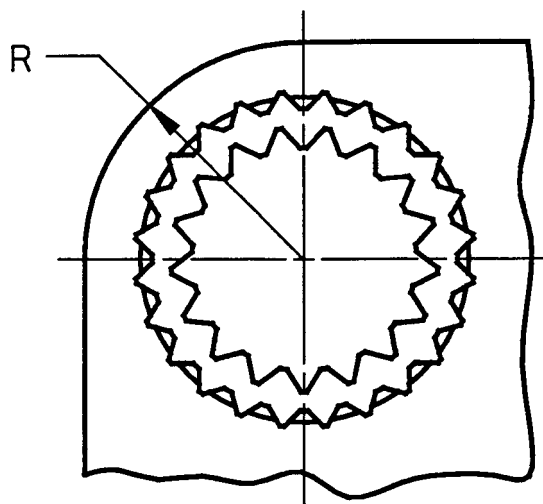

BASIC LOCKRING PART NUMBER	CBORE DIA +.003 -.000 [2]		R MIN
	ALUM	MAG	
	RL21	.328	.337
RL24	.375	.381	.25
RL28	.437	.448	.31
RL31	.484	.495	.34
RL33	.515	.526	.36
RL38	.593	.601	.42
RL43	.671	.675	.47
RL47	.734	.747	.50
RL56	.875	.888	.62
RL64	1.000	1.015	.69
RL72	1.125	1.139	.75

NOTES: UNLESS OTHERWISE SPECIFIED

1. The minimum boss radius (R) shown is the minimum dimension applicable for lockring installation into either aluminum or magnesium parent material.
- [2] The magnesium counterbore diameters are to be used for application in either magnesium or steel bosses (except for Hydraulic Inserts "RJ1700" series which requires the aluminum counterbore to prevent O-ring from extruding under pressure) refer to page 55.

**DESIGN DATA,
LOCKRING - THIN**

**RL()
SERIES**

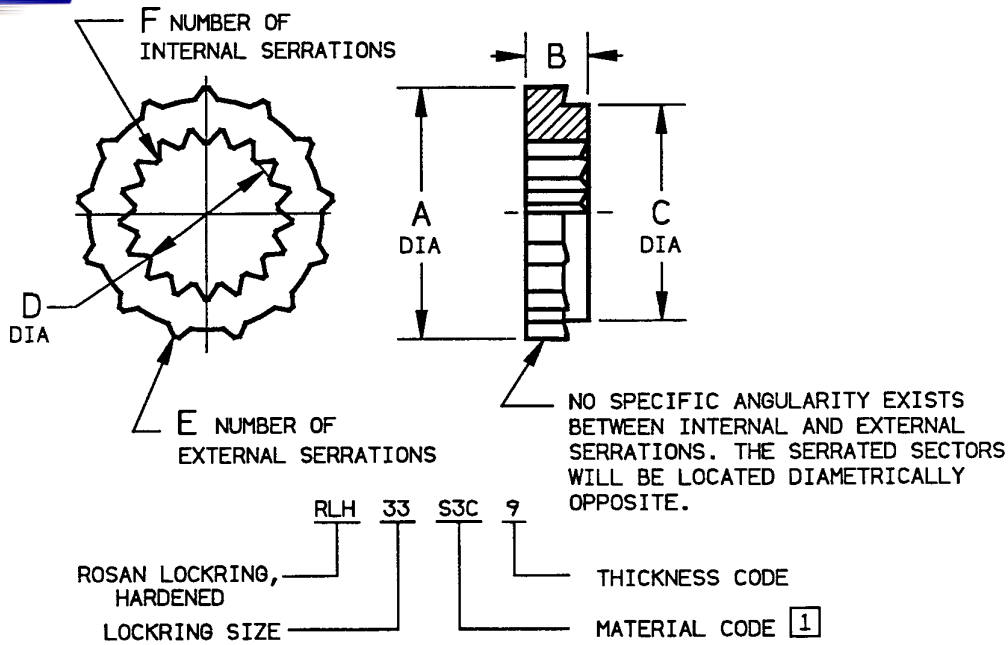

LOCKRING PART NUMBER	A DIA	B	C DIA	D DIA	E	F
	+005 -004	±.005	±.005	+004 -003		
RLH16S3C4	.274	.068	.223	.161	10	14
RLH18S3C4	.308	.068	.255	.189	10	16
RLH21S3C4	.354	.068	.298	.213	12	13
RLH24S3C5	.399	.081	.343	.266	12	17
RLH28S3C5	.468	.081	.400	.323	13	20
RLH31S3C6	.514	.099	.452	.375	15	23
RLH33S3C6	.545	.099	.480	.390	17	24
RLH38S3C7	.624	.115	.560	.468	18	26
RLH43S3C7	.699	.115	.636	.520	18	26
RLH47S3C8	.767	.130	.702	.574	20	26
RLH56S3C8	.910	.130	.837	.695	22	30
RLH64S3C8	1.040	.130	.958	.795	19	30
RLH72S3C8	1.170	.130	1.078	.908	20	38
RLH82S3C9	1.326	.145	1.232	1.035	18	36
RLH90S3C9	1.456	.145	1.371	1.189	18	48
RLH100S3C9	1.611	.145	1.509	1.282	16	42

- NOTES: UNLESS OTHERWISE SPECIFIED
- [1] MATERIAL: Inconel 718 (AMS5662).
 2. HEAT TREAT: 230 KSI UTS MIN.
 3. FINISH: Passivate per QQ-P-35
 4. These lockrings will penetrate into most materials of hardness up to 40 HRC.
 5. For specific hole preparation and installation information refer to TSB89-0526.

LOCKRING - SELF BROACHING

**RLH()
SERIES**

INTERCHANGEABILITY TABLES

INSERTS

MS* PART NUMBER	ROSAN* PART NUMBER
MS5191-102	RJ102SB4
MS5191-103	RJ103SB5
MS5191-104	RJ104SB6
MS5191-105	RJ105SB7
MS5191-106	RJ106SB8
MS5191-107	RAJ107SB9
MS5191-108	RJ108SB10
MS5191-109	RJ109SB11
MS5191-110	RJ110SB12
MS5191E102	RJ102SU4
MS5191E103	RJ103SU5
MS5191E104	RJ104SU6
MS5191E105	RJ105SU7
MS5191E106	RJ106SU8
MS5191E107	RAJ107SU9
MS5191E108	RJ108SU10
MS5191E109	RJ109SU11
MS5191E110	RJ110SU12
MS5191-202	RJ202SB4
MS5191-203	RJ203SB5
MS5191-204	RJ204SB6
MS5191-205	RJ205SB7
MS5191-206	RJ206SB8
MS5191-207	RAJ207SB9

INSERTS

MS* PART NUMBER	ROSAN* PART NUMBER
MS5191-208	RJ208SB10
MS5191-209	RJ209SB11
MS5191-210	RJ210SB12
MS5191E202	RJ202U4
MS5191E203	RJ203SU5
MS5191E204	RJ204SU6
MS5191E205	RJ205U7
MS5191E206	RJ206SU8
MS5191E207	RAJ207SU9
MS5191E208	RAJ207SU10
MS5191E209	RJ209SU11
MS5191E210	RJ210SU12
MS5191-311	RJ311SB14
MS5191-312	RJ312SB16
MS5191-312.1	RJ312SB16F
MS5191-313	RJ313SB18
MS5191-314	RJ314SB20
MS5191-315	RJ315SB22F
MS5191E311	RJ311SU14
MS5191E312	RJ312SU16
MS5191E312.1	RJ312SU16F
MS5191E313	RJ313SU18
MS5191E314	RJ314SU20
MS5191E315	RJ315SU22F

LOCKRINGS

MS PART NUMBER	ROSAN PART NUMBER
MS51990-102P	RLRR16SB5
MS51990-103P	RLRR18SB6
MS51990-104P	RLRR21SB6
MS51990-105P	RLRR24SB7
MS51990-106P	RLRR28SB8
MS51990-107P	RLRR33SB9
MS51990-108P	RLRR38SB9
MS51990-109P	RLRR47SB10
MS1990-110P	RLRR56SB11
MS51990-111P	RLRR64SB11
MS51990-112P	RLRR72SB11
MS51990-113P	RLRR82SB12
MS51990-114P	RLRR90SB12
MS51990-115P	RLRR100SB12
MS5190E102P	RLRR16SU5
MS51990E103P	RLRR18SU6
MS51990E104P	RLRR21SU6
MS51990E105P	RLRR24SU7
MS51990E106P	RLRR28SU8
MS51990E107P	RLRR33SU9
MS51990E108P	RLRR38SU9
MS51990E109P	RLRR47SU10
MS51990E110P	RLRR56SU11
MS51990E111P	RLRR64SU11
MS51990E112P	RLRR72SU11
MS51990E113P	RLRR82SU12
MS51990E114P	RLRR90SU12
MS51990E115P	RLRR100SU12

* Add letter "L" to "MS" part number and Rosan part number for internal thread locking feature.

EXAMPLE: MS51991-102L=RJ102SB4L

MS51991 VS ROSAN INSERTS, MS51990 VS ROSAN LOCKRINGS

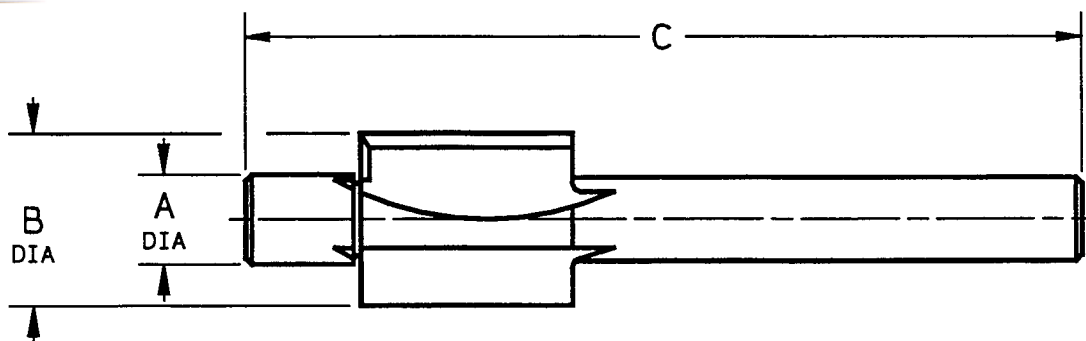

PART NUMBER	A DIA ±.0005	B DIA +.0010 -.0000	C ±.03
RC12-128	.1275	.1870	2.38
RC16-128	.1275	.2500	2.38
RC16-157	.1565	.2500	2.38
RC18-157	.1565	.2810	2.38
RC18-185	.1845	.2810	2.38
RC21-213	.2125	.3280	2.56
RC23-185	.1845	.3590	2.69
RC23-242	.2415	.3590	2.69
RC24-190	.1895	.3750	2.69
RC24-257	.2565	.3750	2.69
RC27-213	.2125	.4210	2.88
RC27-281	.2805	.4210	2.88
RC28-190	.1895	.4370	2.88
RC28-250	.2495	.4370	2.88
RC28-312	.3115	.4370	2.88
RC31-242	.2415	.4840	3.19
RC31-359	.3585	.4840	3.19
RC33-250	.2495	.5150	3.44
RC33-281	.2805	.5150	3.44
RC33-312	.3115	.5150	3.44
RC33-368	.3675	.5150	3.44
RC33-386	.3855	.5150	3.44
RC38-312	.3115	.5930	3.56
RC38-375	.3745	.5930	3.56
RC38-422	.4215	.5930	3.56
RC38-453	.4525	.5930	3.56
RC43-375	.3745	.6710	3.75
RC43-437	.4365	.6710	3.75
RC47-359	.3585	.7335	3.75
RC47-422	.4215	.7340	3.75
RC47-437	.4365	.7340	3.75
RC47-506	.5055	.7340	3.75

PART NUMBER	A DIA ±.0005 .0010	B DIA -.0000	C ±.03
RC47-535	.5345	.7340	3.75
RC47-569	.5685	.7340	3.75
RC51-569	.5685	.7970	4.12
RC56-506	.5055	.8750	4.12
RC56-569	.5685	.8750	4.12
RC56-625	.6245	.8750	4.12
RC56-656	.6555	.8750	4.12
RC56-687	.6865	.8750	4.12
RC64-569	.5685	1.0000	4.12
RC64-625	.6245	1.0000	4.12
RC64-688	.9875	1.0000	4.12
RC64-750	.7495	1.0000	4.12
RC64-765	.7645	1.0000	4.12
RC72-625	.6245	1.1250	4.38
RC72-688	.6875	1.1250	4.38
RC72-813	.8125	1.1250	4.38
RC72-875	.8745	1.1250	4.38
RC72-927	.9265	1.1250	4.38
RC82-750	.7495	1.2810	4.50
RC82-813	.8125	1.2810	4.50
RC82-938	.9375	1.2810	4.50
RC82-1000	.9995	1.2810	4.50
RC90-813	.8125	1.4060	4.75
RC90-875	.8745	1.4060	4.75
RC90-938	.9375	1.4060	4.75
RC90-1094	1.0935	1.4060	4.75
RC90-1125	1.1245	1.4060	4.75
RC100-938	.9375	1.5620	4.75
RC100-1000	.9995	1.5620	4.75
RC100-1094	4.0935	4.5620	4.75
RC124-1094	1.0935	1.9370	4.75
RC124-1125	1.1245	1.9370	4.75

NOTES: UNLESS OTHERWISE SPECIFIED

1. MATERIAL: High speed steel.

**TOOL - COUNTERBORE
FOR ALUMINUM APPLICATIONS**

**RC()
SERIES**

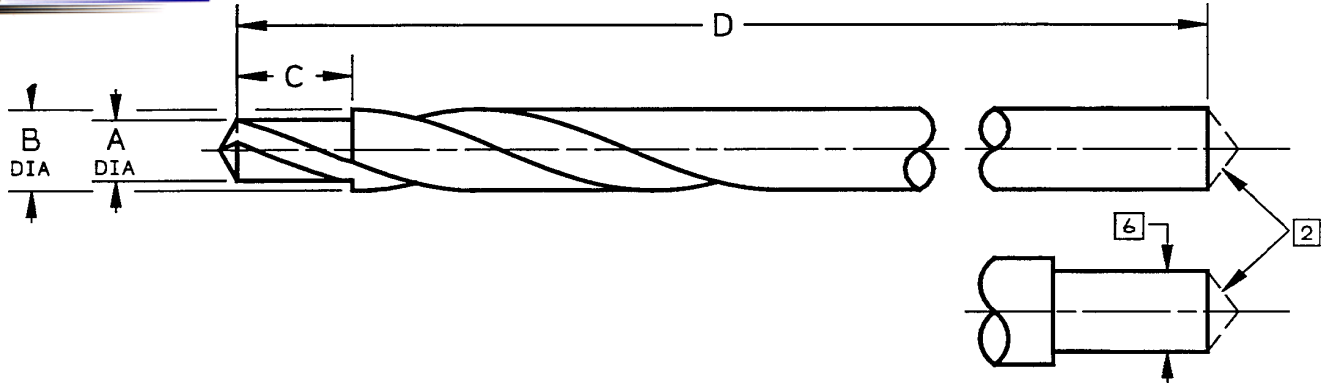

PART NUMBER	A DIA ±.0005	B DIA [7]	C ±.005	D ±.250
RCD16-128	.1280	.250	.312	4.000
RCD16-157	.1570	.250	.312	4.000
RCD18-157	.1570	.281	.375	4.250
RCD18-185	.1850	.281	.375	4.250
RCD21-213	.2130	.328	.437	4.620
RCD23-185	.1850	.359	.500	4.880
RCD23-242	.2420	.359	.500	4.880
RCD24-190	.1900	.375	.500	5.000
RCD27-213	.2130	.421	.562	5.380
RCD27-281	.2810	.421	.562	5.380
RCD28-250	.2500	.437	.562	5.500
RCD31-242	.2420	.484	.625	5.880
RCD31-359	.3590	.484	.625	5.880
RCD33-281	.2810	.515	.625	3.880
RCD33-312	.3120	.515	.625	3.880
RCD33-386	.3860	.515	.625	3.880
RCD38-422	.4220	.593	.687	4.120
RCD38-453	.4530	.593	.687	4.120
RCD43-437	.4370	.671	.750	4.620
RCD47-359	.3590	.734	.750	5.000
RCD47-422	.4220	.734	.750	5.000
RCD47-506	.5060	.734	.750	5.000

PART NUMBER	A DIA ±.0005	B DIA [7]	C ±.005	D ±.250
RCD47-569	.5690	.734	.750	5.000
RCD51-569	.5690	.797	.812	5.250
RCD56-506	.5060	.875	.812	5.500
RCD56-569	.5690	.875	.812	5.500
RCD56-625	.6250	.875	.812	5.500
RCD56-687	.6870	.875	.812	5.500
RCD64-325	.6250	1.000	.937	6.000
RCD64-688	.6880	1.000	.937	6.000
RCD64-750	.7500	1.000	.937	6.000
RCD72-625	.6250	1.125	1.062	6.380
RCD72-688	.6880	1.125	1.062	6.380
RCD72-813	.8130	1.125	1.062	6.380
RCD72-875	.8750	1.125	1.062	6.380
RCD72927	.9270	1.125	1.062	6.380
RCD82-813	.8130	1.281	1.187	7.000
RCD82-938	.9380	1.281	1.187	7.000
RCD82-1000	1.0000	1.281	1.187	7.000
RCD90-813	.8130	1.406	1.312	7.380
RCD90-1094	1.0940	1.406	1.312	7.380
RCD90-1125	1.1250	1.406	1.312	7.380
RCD100-938	.9380	1.562	1.437	7.750
RCD124-1094	1.0940	1.937	1.875	8.500

NOTES: UNLESS OTHERWISE SPECIFIED

1. **MATERIAL:** High speed steel.
- [2] **Conical point optional.**
3. **HEAT TREAT:** Per drill manufacturer's standard.
4. **FINISH:** Strippable plastic coat to protect cutting edges. Tube packaging optional.
5. Made from standard straight shank jobbers or screw machine twist drills.
- [6] Configuration applicable only for part number RCD72-625 thru RCD124-1094.
- [7] For drill tolerances, see ANSI B94.11M.
8. **CAUTION:** Step drills are designed for thru hole drilling. When used to drill a blind hole, it may be necessary to grind the drill to suit the depth required.

**TOOL - STEP DRILL
FOR ALUMINUM APPLICATIONS**

**RCD()
SERIES**

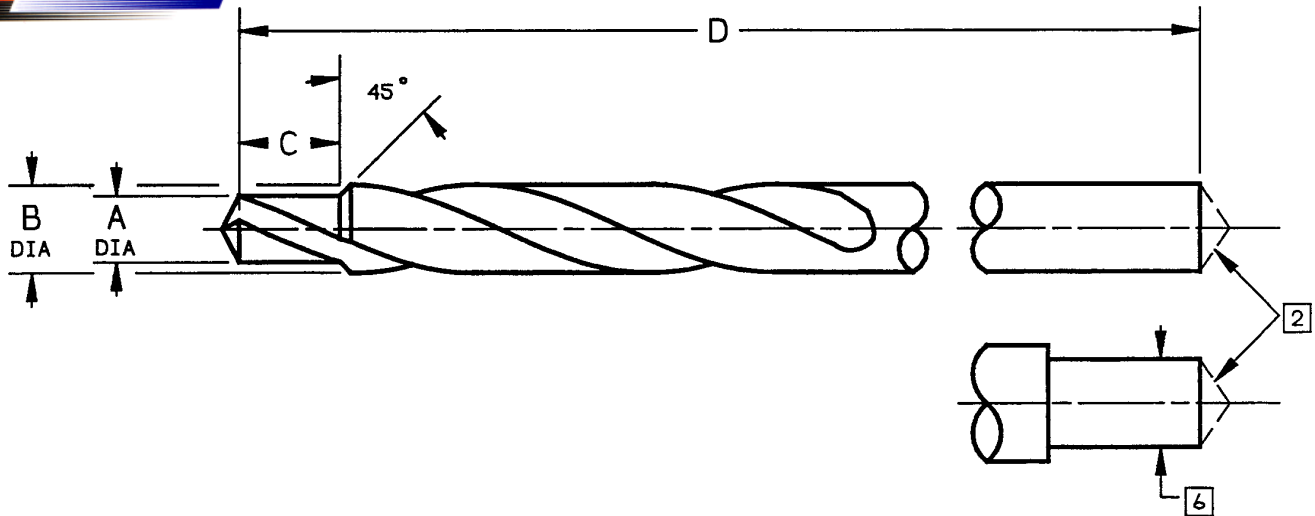

PART NUMBER	A DIA	B DIA	D	
			C ±.005	±.250
RCDC16-136	.1353-.1360	.2570-.2500	.312	4.000
RCDC16-136S	.1353-.1360	.2493-.2500	.274	4.000
RCDC16-149	.1483-.1490	.2493-.2500	.312	4.000
RCDC16-159	.1583-.1590	.2493-.2500	.312	4.000
RCDC18-149	.1483-.1490	.2800-.2810	.375	4.250
RCDC18-149S	.1483-.1490	.2800-.2810	.430	4.250
RCDC18-159	.1583-.1590	.2800-.2810	.375	4.250
RCDC18-159S	.1583-.1590	.2800-.2810	.380	4.250
RCDC18-177	.1763-.1770	.2800-.2810	.375	4.250
RCDC18-180	.1793-.1800	.2800-.2810	.375	4.250
RCDC21-201	.2003-.2010	.3270-.3280	.437	4.750
RCDC21-201S	.2003-.2010	.3270-.3280	.535	4.3750
RCDC21-213	.2123-.2130	.3270-.3280	.437	4.750
RCDC21-213S	.2123-.2130	.3270-.3280	.471	4.750
RCDC23-257	.2560-.2570	.3580-.3590	.500	5.000
RCDC23-257S	.2560-.2570	.3580-.3590	.671	5.000
RCDC23-272	.2710-.2720	.3580-.3590	.500	5.000
RCDC23-272S	.2710-.2720	.3580-.3590	.608	5.000
RCDC24-257	.2560-.2570	.3740-.3750	.500	5.000
RCDC24-257S	.2560-.2570	.3740-.3750	.663	5.000
RCDC24-272	.2710-.2720	.3740-.3750	.500	5.000
RCDC24-272S	.2710-.2720	.3740-.3750	.600	5.000
RCDC24-281	.2800-.2810	.3740-.3750	.312	5.000

PART NUMBER	A DIA	B DIA	D	
			C ±.005	±.250
RCDC24-312	.3110-.3120	.3740-.3750	.500	5.000
RCDC24-312	.3110-.3120	.3740-.3750	.500	5.000
RCDC27-312	.3110-.3120	.4200-.4210	.562	5.500
RCDC27-312S	.3110-.3120	.4200-.4210	.810	5.500
RCDC27-322	.3210-.3220	.4200-.4210	.562	5.500
RCDC27-332	.3310-.3320	.4200-.4210	.562	5.500
RCDC27-332S	.3310-.3320	.4200-.4210	.717	5.500
RCDC28-312	.3110-.3120	.4360-.4370	.562	5.5625
RCDC28-312S	.3110-.3120	.4360-.4370	.720	5.625
RCDC28-322	.3210-.3220	.4360-.4370	.562	5.625
RCDC28-332	.3310-.3320	.4360-.4370	.562	5.625
RCDC28-332S	.3310-.3320	.4360-.4370	.709	5.625
RCDC28-343	.3420-.3430	.4360-.4370	.562	5.625
RCDC28-368	.3670-.3680	.4360-.4370	.562	5.625
RCDC28-386	.3850-.3860	.4360-.4370	.629	5.625
RCDC28-404	.4030-.4040	.4360-.4370	.614	5.625
RCDC31-368	.3670-.3680	.4830-.4840	.625	6.000
RCDC31-386	.3850-.3860	.4830-.4840	.625	6.000
RCDC33-368	.3670-.3680	.5138-.5150	.625	3.875
RCDC33-368S	.3670-.3680	.5138-.5150	.879	3.875
RCDC33-386	.3850-.3860	.5138-.5150	.625	3.875
RCDC33-386S	.3850-.3860	.5138-.5150	.785	3.875
RCDC33-422	.4210-.4220	.5138-.5150	.625	3.875

NOTES: UNLESS OTHERWISE SPECIFIED

- 1. MATERIAL: High speed steel.
- [2] Conical point optional.

**TOOL - CHAMFERED STEP DRILL
FOR ALUMINUM APPLICATIONS**

**RCDC()
SERIES**

PART NUMBER	A DIA	B DIA	C ±.005	D ±.250
RCDC33-422S	.4210-.4220	.5138-.5150	.881	3.875
RCDC33-453	.4520-.4530	.5138-.5150	.759	3.875
RCDC38-368S	.3670-.3680	.5918-.5930	.960	4.250
RCDC38-422	.4210-.4220	.5918-.5930	.687	4.250
RCDC38-422S	.4210-.4220	.5918-.5930	.960	4.250
RCDC38-453	.4520-.4530	.5918-.5930	.687	4.250
RCDC38-453S	.4520-.4530	.5918-.5930	.841	4.250
RCDC38-484	.4830-.4840	.5918-.5930	.687	4.250
RCDC38-506	.5050-.5060	.5918-.5930	.739	4.250
RCDC38-516	.5148-.5160	.5918-.5930	.893	4.250
RCDC43-578	.5768-.5780	.6698-.6710	1.050	4.500
RCDC47-484	.4830-.4840	.7328-.7340	.750	5.000
RCDC47-484S	.4830-.4840	.7328-.7340	.997	5.000
RCDC47-506	.5050-.5060	.7328-.7340	.750	5.000
RCDC47-506S	.5050-.5060	.7328-.7340	.870	5.000
RCDC47-535	.538-.5350	.7328-.7340	.750	5.000
RCDC47-535S	.5338-.5350	.7328-.7340	1.185	5.000
RCDC47-569	.5678-.5690	.7328-.7340	.750	5.000
RCDC47-569S	.5678-.5690	.7328-.7340	1.026	5.000
RCDC56-656	.6548-.6560	.8738-.8750	.812	5.375
RCDC56-656S	.6548-.6560	.8738-.8750	1.325	5.375
RCDC56-687	.6548-.6570	.8738-.8750	.812	5.375

PART NUMBER	A DIA	B DIA	C ±.005	D ±.250
RCDC56-687S	.6858-.6870	.8738-.8750	1.168	5.375
RCDC56-802S	.8008-.8020	.8738-.8750	1.546	5.375
RCDC64-765	.7638-.7650	.9988-1.0000	.937	6.000
RCDC64-765S	.7638-.7650	.9988-1.0000	1.432	6.000
RCDC64-802	.8008-.8020	.9988-1.0000	.937	6.000
RCDC64-802S	.8008-.8020	.9988-1.0000	1.432	6.000
RCDC72-875	.8738-.8750	1.1235-1.1250	1.062	6.000
RCDC72-922	.9208-.9220	1.1235-1.1250	1.062	6.000
RCDC72-927	.9258-.9270	1.1235-1.1250	1.062	6.000
RCDC72-927S	.9258-.9270	1.1235-1.1250	1.137	6.000
RCDC72-938	.9368-.9380	1.1235-1.1250	1.062	6.000
RCDC82-984	.9828-.9840	1.2795-1.2810	1.187	7.000
RCDC82-1000	.9988-1.0000	1.2795-1.2810	1.187	7.000
RCDC82-1043	1.0415-1.0430	1.2795-1.2810	1.187	7.000
RCDC82-1043S	1.0415-1.0430	1.2795-1.2810	1.812	7.000
RCDC82-1165	1.1635-1.1650	1.2795-1.2810	1.1812	7.000
RCDC90-1109	1.1075-1.1090	1.4045-1.4060	1.312	7.375
RCDC90-1165	1.1635-1.1650	1.4045-1.4060	1.312	7.375
RCDC100-1228	1.2265-1.2280	1.5605-1.5620	1.437	7.750
RCDC100-1289	1.2875-1.2890	1.5605-1.5620	1.437	7.750
RCDC124-1546	1.5445-1.5460	1.9355-1.9370	1.870	8.500
RCDC124-1656	1.6545-1.6560	1.9355-1.9370	1.940	8.500
RCDC124-1789	1.7875-1.7890	1.9355-1.9370	2.560	8.500

NOTES: CONTINUED

3. **HEAT TREAT:** Per drill manufacturer's standard.
4. **FINISH:** Strippable plastic coat to protect cutting edges. Tube packaging optional.
5. Made from standard straight shank jobbers or screw machine twist drills.
- [6] Configuration applicable only for part number RCDC72-875 thru RCDC124-1789.
7. Dimensions and tolerances not shown are per ANSI B94.11M.
8. **CAUTION:** Step drills are designed for thru hole drilling. When used to drill a blind hole, it may be necessary to grind the drill to suit the depth required.

**TOOL - CHAMFERED STEP DRILL
FOR ALUMINUM APPLICATIONS**

**RCDC()
SERIES**

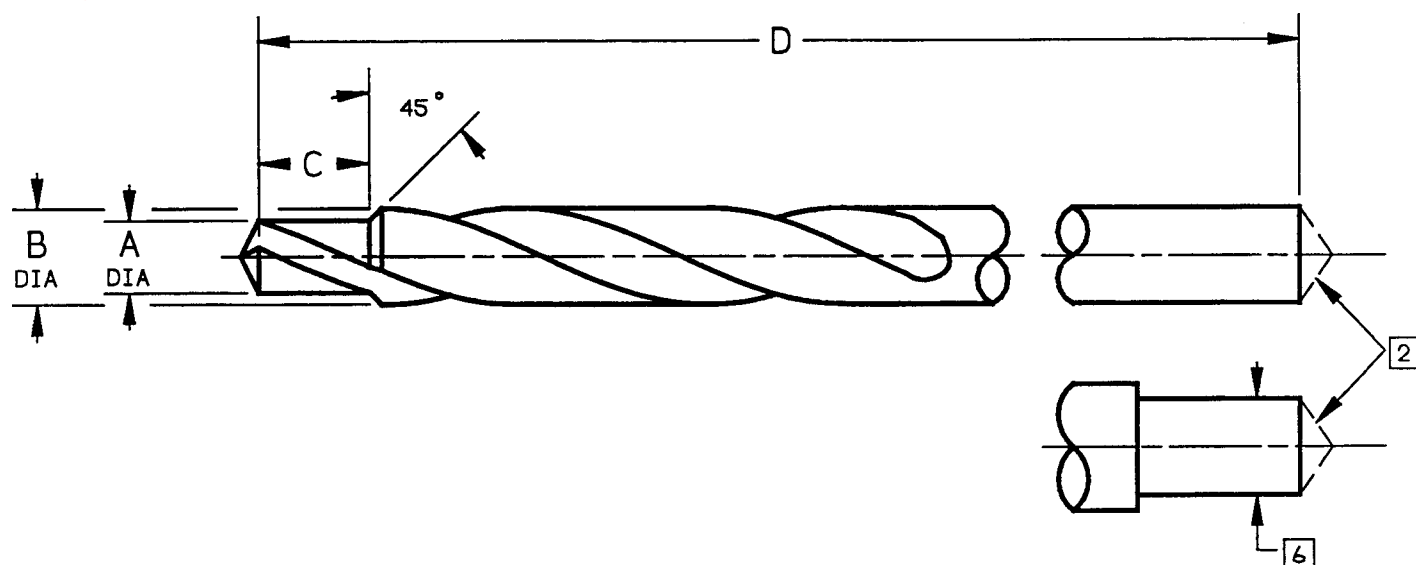

PART NUMBER	A DIA	B DIA	D	
			±.005	±.250
RCADC16-136	.1353-.1360	.2570-.2580	.312	4.125
RCADC16-149	.1483-.1490	.2570-.2580	.312	4.125
RCADC16-159	.1583-.1590	.2570-.2580	.312	4.125
RCADC18-149	.1483-.1490	.2900-.2910	.375	4.375
RCADC18-149S	.1483-.1490	.2900-.2910	.435	4.375
RCADC18-159S	.1583-.1590	.2900-.2910	.435	4.375
RCADC18-177	.1763-.1770	.2900-.2910	.375	4.375
RCADC18-180	.1793-.1800	.2900-.2910	.375	4.375
RCADC21-201	.2003-2010	.3360-.3370	.437	4.750
RCADC21-201	.2003-2010	.3360-.3370	.437	4.750
RCADC21-201S	.2003-2010	.3360-.3370	.540	4.750
RCADC21-213	.2123-.2130	.3360-.3370	.437	4.750
RCADC21-213S	.2123-.2130	.3360-.3370	.471	4.750
RCADC23-257	.2560-.2570	.3690-.3700	.500	5.000
RCADC23-257S	.2560-.2570	.3690-.3700	.671	5.000
RCADC23-272	.2710-.2720	.3690-.3700	.500	5.000
RCADC23-272S	.2710-.2720	.3690-.3700	.608	5.000
RCADC24-257	.2560-.2570	.3800-.3810	.500	5.125
RCADC24-257S	.2560-.2570	.3800-.3810	.588	5.125
RCADC24-272	.2710-.2720	.3800-.3810	.500	5.125

PART NUMBER	A DIA	B DIA	D	
			±.005	±.250
RCADC24-312	.3110-.3120	.3800-.3810	.500	5.125
RCADC24-332	.3310-.3320	.3800-.3810	.482	5.125
RCADC27-312	.3110-.3120	.4310-.4320	.562	5.500
RCADC27-312S	.3110-.3120	.4310-.4320	.810	5.500
RCADC27-332	.3310-.3320	.4310-.4320	.562	5.500
RCADC27-332S	.3310-.3320	.4310-.4320	.717	5.500
RCADC28-312	.3110-.3120	.4470-.4480	.562	5.625
RCADC28-312S	.3110-.3120	.4470-.4480	.807	5.625
RCADC28-332	.3310-.3320	.4470-.4480	.562	5.625
RCADC28-332	.3310-.3320	.4470-.4480	.562	5.625
RCADC28-332S	.3310-.3320	.4470-.4480	.709	5.625
RCADC28-343	.3420-.3430	.4470-.4480	.562	5.625
RCADC28-368	.3670-.3680	.4470-.4480	.562	5.625
RCADC31-368	.367-.3680	.4940-.4950	.625	6.000
RCADC31-386	.3850-.3860	.4940-.4950	.625	6.000
RCADC31-368	.3670-.3680	.5248-.5260	.625	3.875
RCADC31-368S	.3670-.3680	.5248-.5260	.792	3.875
RCADC33-386	.3850-.3860	.5248-.5260	.625	3.875
RCADC33-386S	.3850-.3860	.5248-.5260	.783	3.875
RCADC33-422	.4210-.4220	.5248-.5260	.625	3.875

NOTES: UNLESS OTHERWISE SPECIFIED

1. MATERIAL: High speed steel.

[2] Conical point optional.

**TOOL - CHAMFERED STEP DRILL
FOR MAGNESIUM APPLICATIONS**

**RCADC ()
SERIES**

PART NUMBER	A DIA	B DIA	C ±.005	D ±.250
RCADC38-422S	.4210-.4220	.5998-.6010	.960	4.250
RCADC38-453	.4520-.4530	.5998-.6010	.687	4.250
RCADC38-453S	.4520-.4530	.5998-.6010	.915	4.250
RCADC38-484	.4830-.4840	.5998-.6010	.687	4.250
RCADC38-506	.5050-.5060	.5998-.6010	.687	4.250
RCADC38-516	.5148-.5160	.5998-.6010	.893	4.250
RCADC43-578	.5768-.5780	.6733-.6745	1.050	4.500
RCADC47-484S	.4830-.4840	.7458-.7470.997	.997	5.000
RCADC47-506S	.5050-.5060	.7458-.7470	.870	5.000
RCADC47-535	.5338-.5350	.7458-.7470	.750	5.000
RCADC47-535S	.5338-.5350	.7458-.7470	1.185	5.000
RCADC47-569	.5678-.5690	.7458-.7470	750	5.000
RCADC47-569S	.5678-.5690	.7458-.7470	1.026	5.000
RCADC56-	.6548-.6560	.8868-.8880	.812	5.625
RCADC56-656S	.6548-.6560	.8868-.8880	1.325	5.625
RCADC56-687	.6858-.6870	.8868-.8880	.812	5.625
RCADC56-687S	.6858-.6870	.8868-.8880	1.168	5.625
RCADC56-802S	.8008-.8020	.8868-.8880	1.556	5.625

PART NUMBER	A DIA	B DIA	C ±.005	D ±.250
RCADC64-765	.7638-.7650	1.0135-1.0150	.937	6.000
RCADC64-765S	.7638-.7650	1.0135-1.0150	1.432	6.000
RCADC64-802	.8008-.8020	1.0135-1.0150	.937	6.000
RCADC64-802S	.8008-.8020	1.0135-1.0150	1.432	6.000
RCADC64-927	.9258-.9270	1.0135-1.0150	.937	6.000
RCADC72-875	.8738-.875	1.1375-1.1390	1.062	6.625
RCADC72-875S	.8738-.8750	1.1375-1.1390	1.965	6.625
RCADC72-922	.9208-.9220	1.1375-1.1390	1.062	6.625
RCADC72-927	.9258-.9270	1.1375-1.1390	1.062	6.625
RCADC72-953	.9518-.9530	1.1375-1.1390	.970	6.625
RCADC82-984	.9828-.9840	1.2965-1.2980	1.187	7.000
RCADC82-1043	1.0415-1.0430	1.2965-1.2980	1.187	7.000
RCADC82-1043S	1.0415-1.0430	1.2965-1.2980	1.812	7.000
RCADC82-1165	1.1635-1.1650	1.2965-1.2980	1.812	7.000
RCADC90-1109	1.1075-1.1090	1.4255-1.4270	1.312	7.375
RCADC90-1165	1.1635-1.1650	1.4255-1.4270	1.312	7.375
RCADC100-1228	1.2265-1.2280	1.5775-1.5790	1.437	7.750
RCADC100-1289	1.2875-1.2890	1.5775-1.5790	1.437	7.750
RCADC124-1531	1.5295-1.5310	1.9515-1.9530	1.625	8.500

NOTES: CONTINUED

3. **HEAT TREAT:** Per drill manufacturer's standard.
4. **FINISH:** Strippable plastic coat to protect cutting edges. Tube packaging optional.
5. Made from standard straight shank jobbers or screw machine twist drills.
- [6] Configuration applicable only for part number RCDC72-875 thru RCDC124-1789.
7. Dimensions and tolerances not shown are per ANSI B94.11M.
8. **CAUTION:** Step drills are designed for thru hole drilling. When used to drill a blind hole, it may be necessary to grind the drill to suit the depth required.

**TOOL - CHAMFERED STEP DRILL
FOR MAGNESIUM APPLICATIONS**

**RCACD()
SERIES**

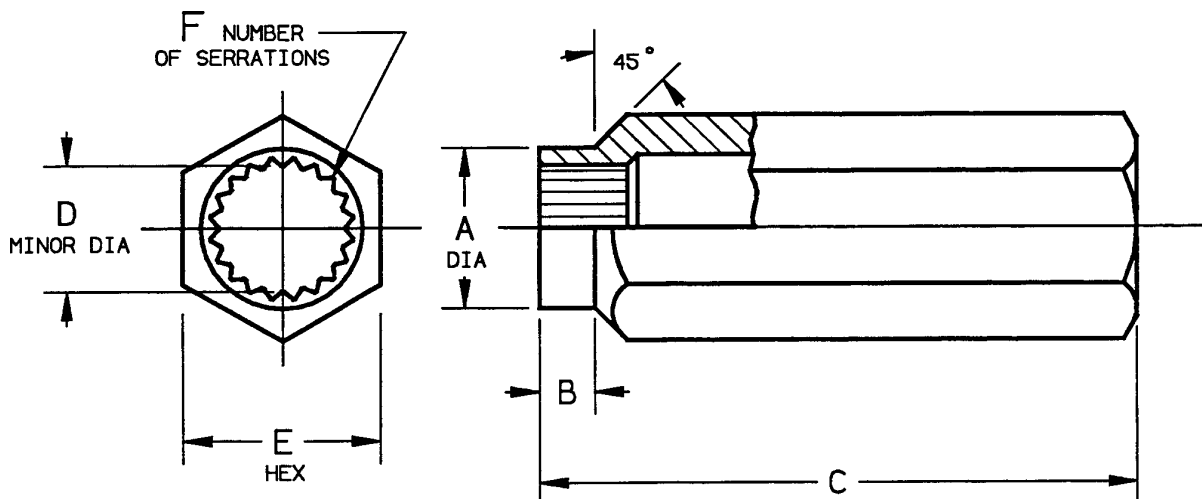

WRENCH PART NUMBER	A DIA MAX	B	C	D DIA	E HEX	F
		±.015	±.3	±.005	REF	
R1100W	.150	.047	1.00	.096	.25	12
R1101W	.180	.063	1.00	.129	.31	12
R1102W	.240	.078	1.50	.161	.38	14
R1103W	.269	.094	1.50	.189	.48	16
R1104W	.313	.094	1.50	.213	.38	13
R1105W	.350	.125	1.50	.266	.50	17
R1106W	.410	.141	1.50	.323	.50	20
R1107W	.470	.156	1.75	.375	.62	23
R1107XW	.500	.156	1.75	.390	.62	24
R1108W	.582	.156	2.00	.468	.75	26
R1109W	.658	.156	2.00	.517	.75	26
R1110W	.723	.172	2.00	.574	1.00	26
R1111W	.862	.188	2.25	.695	1.00	30
RR1112W	.985	.188	2.50	.795	1.38	30
R1113W	1.110	.188	2.50	.908	1.38	38
R1114W	1.265	.188	2.50	1.035	1.50	36
R1115W	1.390	.188	2.50	1.189	1.50	48
R1116W	1.547	.188	2.50	1.282	1.75	42
R1117W	1.907	.219	3.00	1.577	2.25	50

NOTES: UNLESS OTHERWISE SPECIFIED

1. MATERIAL: 4140 (MIL-S-5626), 4340 (MIL-S-5000 or 8740 (AMS6322).
2. HEAT TREAT: 160-180 KSI UTS.
3. FINISH: Black oxide plus oil.

WRENCH

**R1100W
SERIES**

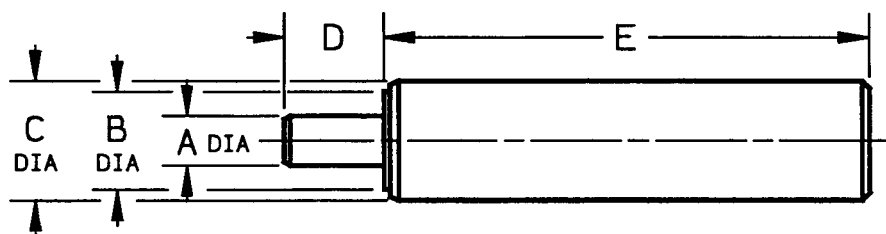

LOCKRING DRIVE TOOL	A DIA ±.005	B DIA ±.005	C DIA ±.015	D ±.015	E ±.03
R102D	.081	.241	.310	.190	2.00
R103D	.100	.272	.380	.250	2.00
R104D	.126	.319	.440	.250	2.00
R105D	.140	.330	.440	.310	2.00
R106D	.190	.412	.500	.410	2.00
R107D	.247	.475	.56	.440	2.00
RA107D	.247	.506	.620	.440	2.00
R108D	.303	.584	.690	.500	2.00
R109D	.657	.725	.810	.500	2.00
R110D	.412	.866	1.000	.500	2.00
R111D	.468	.979	1.120	.620	2.50
R112D	.522	1.095	1.250	.620	2.50
R113D	.637	1.245	1.500	.620	2.50
R114D	.750	1.354	1.620	.750	3.00
R115D	.860	1.502	1.750	.750	3.00
R205D	.152	.345	.440	.10	2.00
R206D	.208	.412	.500	.410	2.00
R207D	.263	.475	.560	.440	2.00
RA207D	.263	.506	.620	.440	2.00

LOCKRING DRIVE TOOL	A DIA ±.005	B DIA ±.005	C DIA ±.015	D ±.015	E ±.03
R208D	.325	.584	.690	.500	2.00
R209D	.379	.725	.810	.500	2.00
R210D	.441	.866	1.000	.500	2.00
R211D	.498	.979	1.120	.620	2.50
R212D	.560	1.095	1.25	.620	2.50
R213D	.677	1.245	1.500	.620	2.50
R214D	.792	1.354	1.620	.750	3.00
R215D	.917	1.502	1.750	.750	3.00
R315D	.905	1.02	1.750	.750	3.00
R1706D	.208	.506	.620	.410	2.00
R1707D	.263	.584	.690	.500	2.00
R1708D	.327	.725	.810	.410	2.00
R1711D	.498	.866	1.000	.620	2.00
R1713D	.677	1.095	1.250	.620	2.50
R3604D	.125	.319	.440	.150	2.00
R3605D	.150	.345	.440	.180	2.00
R3606D	.205	.412	.500	.250	2.00
R3607D	.260	.475	.630	.340	2.00
R3608D	.324	.584	.750	.500	2.00
R3609D	.375	.662	.880	.620	2.00

LOCKRING DRIVE TOOL	E ±.03	F DIA ±.005	G DIA ±.015
R1102D	2.00	.241	.310
R1103D	2.00	.272	.380
R1104D	2.00	.319	.440
R1105D	2.00	.330	.440
R1106D	2.00	.412	.500
R1107D	2.00	.475	.560
R1108D	2.00	.584	.690
R1110D	2.00	.725	.810
R1111D	2.00	.865	1.000
R1112D	2.00	.979	1.120
R1113D	2.00	1.095	1.250

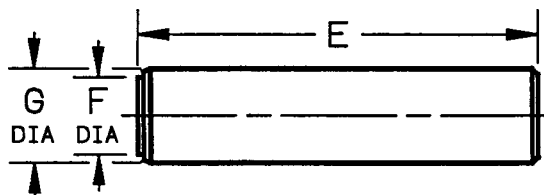

- NOTES: UNLESS OTHERWISE SPECIFIED
1. MATERIAL: Alloy Steel.
 2. HEAT TREAT: Heat Treated.
 3. FINISH: Black oxide plus oil.

LOCKRING DRIVE TOOL

**R()D
SERIES**

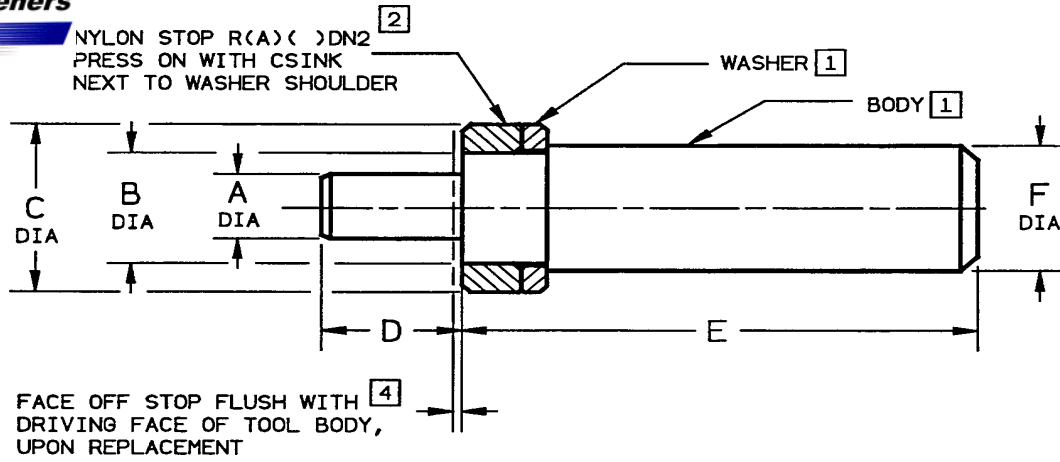

DRIVE TOOL NUMBER	A DIA ±.005	B DIA REF	C DIA ±.015	D ±.015	E DIA ±.03	F PART ±.015	NYLON STOP TOOL NUMBER [2]
R102DN	.081	.238	.460	.190	2.00	.310	R102DN2
R103DN	.100	.268	.490	.250	2.00	.380	R103DN2
R104DN	.126	.316	.540	.250	2.00	.440	R104DN2
R105DN	.140	.326	.550	.310	2.00	.440	R105DN2
R106DN	.190	.408	.660	.410	2.00	.500	R106DN2
R107DN	.247	.472	.720	.440	2.00	.560	R107DN2
RA107DN	.247	.503	.750	.440	2.00	.620	RA107DN2
R108DN	.303	.582	.890	.500	2.00	.690	R108DN2
R109DN	.357	.722	1.03	.500	2.00	.810	R109DN2
R110DN	.412	.864	1.170	.500	2.00	1.000	R110DN2
R111DN	.468	.976	1.380	.620	2.50	1.120	R111DN2
R112DN	.522	1.092	1.510	.620	2.50	1.250	R112DN2
R113DN	.637	1.242	1.680	.620	2.50	1.500	R113DN2
R114DN	.750	1.352	1.810	.750	3.00	1.620	R114DN2
R115DN	.860	1.500	1.980	.750	3.00	1.750	R115DN2
R205DN	.152	.342	.560	.310	2.00	.440	R205DN2
R206DN	.208	.408	.660	.410	2.00	.500	R106DN2
R207DN	.263	.472	.720	.440	2.00	.560	R107DN2
RA207DN	.263	.503	.75	.440	2.00	.620	RA107DN2

DRIVE DIA NUMBER	A DIA ±.005	B DIA REF	C ±.015	D ±.015	E ±.03	F DIA ±.015	NYLON STOP PART NUMBER [2]
R208DN	.325	.582	.890	.500	2.00	.690	R108DN2
R209DN	.379	.722	1.030	.500	2.00	.810	R109DN2
R210DN	.441	.864	1.170	.500	2.00	1.000	R110DN2
R211DN	.498	.976	1.380	.620	2.50	1.120	R111DN2
R212DN	.560	1.092	1.510	.620	2.50	1.250	R112DN2
R213DN	.677	1.242	1.680	.620	2.50	1.5	R113DN2
R214DN	.792	1.352	1.810	.750	3.00	1.620	R114DN2
R215DN	.917	1.500	1.980	.750	3.00	1.75	R115DN2
R315DN	.905	1.500	1.980	.750	3.00	1.750	R115DN2
R1706DN	.208	.503	.750	.410	2.00	.620	RA107DN2
R1707DN	.263	.582	.890	.500	2.00	.690	R108DN2
R1708DN	.327	.722	1.030	.410	2.00	.810	R109DN2
R1711DN	.498	.864	1.170	.620	2.00	1.000	R110DN2
R1713DN	.677	1.092	1.510	.620	2.50	1.250	R112DN2
R3604DN	.125	.316	.540	.150	2.00	.440	R104DN2
R3605DN	.150	.342	.560	.180	2.00	.440	R205DN2
R3606DN	.205	.408	.660	.250	2.00	.500	R106DN2
R3607DN	.260	.472	.720	.340	2.00	.630	R107DN2
R3608DN	.324	.582	.890	.500	2.00	.750	R108DN2
R3609DN	.375	.660	.960	.620	2.00	.880	R3609DN2

NOTES: UNLESS OTHERWISE SPECIFIED

[1] BODY AND WASHER: 4130 Steel, heat treated, black oxide and rust preventive oil.

Alternate material: Stress proof.

[2] Replacement nylon stops are available: See above table for part numbers.

3. R100DN, R200DN, R1700DN and R3600DN Series insert lockring drive tools may be used in place of R()D Series insert lockring drive tools. EXAMPLE:

RA107DN may be used in place of RA107D; R208DN may be used in place of R208D.

R1711DN may be used in place of R1711D R3605DN may be used in place of R3605D.

In process of driving the lockring, the nylon stop will prevent possible marks on the parent material surface.

[4] Replacement of nylon stop becomes necessary when lockring installation depth no longer meets requirements per applicable specification.

LOCKRING DRIVE TOOL, WITH NYLON STOP

**R()
SERIES**

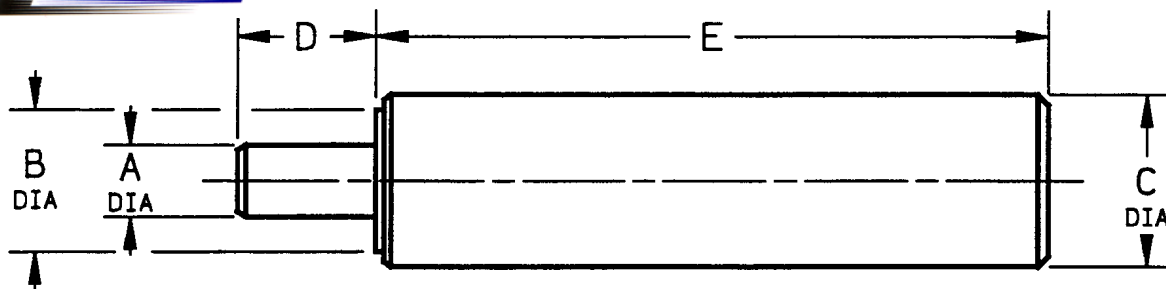

LOCKRING DRIVE TOOL	A DIA ±.005	B DIA ±.005	C DIA ±.015	D ±.015	E ±.03
R102DH	.081	.276	.375	.190	2.00
R103DH	.100	.310	.438	.250	2.00
R104DH	.126	.356	.500	.250	2.00
R105DH	.140	.401	.500	.310	2.00
R106DH	.190	.470	.562	.410	2.00
R107DH	.247	.516	.625	.440	2.00
R108DH	.303	.626	.750	.500	2.00
R109DH	.357	.769	.875	.500	2.00
R110DH	.412	.912	1.125	.500	2.00
R111DH	.468	1.042	1.250	.620	2.50
R112DH	.522	1.172	1.375	.620	2.50
R113DH	.637	1.328	1.500	.620	2.50
R114DH	.750	1.458	1.625	.750	3.00
R115DH	.860	1.613	1.750	.750	3.00
R205DH	.152	.401	.500	.310	2.00
R206DH	.208	.470	.562	.410	2.00
R207DH	.263	.516	.625	.440	2.00
RA207DH	.263	.547	.690	.440	2.00
R208DH	.325	.626	.750	.500	2.00

LOCKRING DRIVE TOOL	A DIA ±.005	B DIA ±.005	C DIA ±.015	D .015	E ±.03
R209DH	.379	.769	.875	.500	2.00
R210DH	.436	.912	1.125	.500	2.00
R211DH	.498	1.042	1.250	.620	2.50
R212DH	.560	1.172	1.375	.620	2.50
R213DH	.677	1.328	1.500	.620	2.50
R214DH	.792	1.458	1.625	.750	3.00
R215	.917	1.613	1.750	.750	3.00
R315DH	.905	1.502	1.750	.750	3.00
R1706DH	.208	.547	.688	.410	2.00
R1707DH	.263	.626	.750	.500	2.00
R1708DH	.327	.769	.875	.410	2.00
R1711DH	.498	.912	1.125	.620	2.00
R1713DH	.677	1.172	1.375	.620	2.50

LOCKRING DRIVE TOOL	A DIA ±.005	B DIA ±.005	C DIA ±.015	D ±.015	E ±.03
R3604DH	.125	.355	.500	.150	2.00
R3605DH	.150	.400	.500	.180	2.00
R3606DH	.205	.469	.560	.250	2.00
R3607DH	.260	.546	.690	.340	2.00
R3608DH	.324	.625	.750	.500	2.00
R3609DH	.375	.700	.880	.620	2.00

- NOTES: UNLESS OTHERWISE SPECIFIED**
- 1. MATERIAL:** Steel, alloy 6150 (MIL-S-8503)
 - 2. HEAT TREAT:** 48-60HRC.
 - 3. FINISH:** Black oxide plus oil.

**LOCKRING DRIVE TOOL
FOR SELF BROACHING LOCKRINGS**

**R()DH
SERIES**

ENGINEERING INFORMATION

PURPOSE - APPLICATION:

Rosan ring-locked inserts are primarily designed to provide:

- *A high strength connection in soft base materials, such as aluminum and magnesium.*
- *An internal thread locking feature in a casting or housing.*
- *Restoration of a damaged thread to its original size.*

DESIGN FEATURES:

The insert external thread has increased pitch and minor diameters (exception RJ1700 series) which result in a slight interference with the tapped hole and provide a snug to tight fit in the parent material. The locking is engaging the insert serrations while the external teeth are imbedded in the base material, thus providing a positive anti-rotational device.

USE - INSTALLATION:

IN SOFT BASE MATERIALS

HOLE PREPARATION: *Per catalog instructions; use “AL” counterbore dimensions for aluminum, “MAG” counterbore dimensions for magnesium base materials (Exception: Hydraulic insert RJ1700 series).*

INSERT INSTALLATION: *The insert oversize external thread may result in light to moderate interference when installed into the parent material hole. To overcome the torque build-up, use of the appropriate Rosan wrench which engages the insert serration is highly recommended.*

If it is felt that torque is excessive, a tap with a higher pitch diameter limit may be used.

Example: *Normally used -GH3, increase to -GH5.*

LOCKRING INSTALLATION: *The lockring is driven into the parent material by use of impact method such as hammer blows or arbor press. The standard lockring will self-broach into materials such as aluminum, magnesium and normalized steel with hardness up to HRB96.*

IN HARDER BASE MATERIALS

HOLE PREPARATION: *Per catalog instructions; use “MAG” counterbore dimensions (Exception: Hydraulic insert RJ1700 series).*

Note: *The interference between insert and parent material thread must be eliminated by selecting one of the following options.*

- *Request insert with standard class 3A external thread configuration. For correct call-out see “insert thread” below.*
- *Tap parent material thread oversize.*

INSERT THREAD: *When an insert with standard class 3A external thread is required, add the following engineering order suffix to part number:*

External thread per MIL-S-7742 class 3A = EO254

External thread per MIL-S-8879 class 3A = EO302

Example: *RJ206SB8E0254*

LOCKRING USAGE AND INSTALLATION:

• *Materials with hardness up to HRC 34 can be broached by carbon steel lockrings with added suffix “E0238”; example: RL38SB7E0238.*

• *Materials, such as 17-4 PH Cres, Inconel 718, A286 Cres and Titanium of hardness up to HRC 40 can be self-broached by RLH(S)3C() series lockring made of cold reduced Inconel 718.*

For modified hole preparation and installation procedure, please request Rosan Technical Sales Bulletin TSB89-0526.

• *The lockring external serration configuration may also be pre-broached into the base material with hardness of up to HRC 40 by using broach tool RLPB-series.*

For special installation hole preparation and tool usage refer to Rosan Technical Bulletin TSB88-1013.

United States Customer Teams

• REGIONAL OFFICES •

Customer Team Washington D.C.

45025 Aviation Drive, Suite 2
Dulles, VA 20166 USA
Tel: 703.742.4450
Fax: 703.742.4451

Customer Team Dallas

701 Highlander Boulevard, Suite 450
Arlington, TX 76015 USA
Tel: 817.417.0677
Fax: 817.417.0678

Customer Team Los Angeles

3016 West Lomita Boulevard
Torrance, CA 90505 USA
Tel: 310.784.0700
Fax: 310.784.6665

Customer Team Seattle

Fisher Business Center, Suite 605
3400 188th Street S.W.
Lynnwood, WA 98037 USA
Tel: 425.712.1599
Fax: 425.744.1283

• DISTRIBUTION OFFICES •

Customer Team-Distribution Dallas

701 Highlander Boulevard, Suite 360
Arlington, TX 76015 USA
Tel: 817.417.4128
Fax: 817.417.4129

Customer Team-Worldwide Distribution Los Angeles

3016 West Lomita Boulevard
Torrance, CA 90505 USA
Tel: 310.784.6400
Fax: 310.784.6608

European Customer Teams

• AEROSPACE OFFICES •

Customer Team Hildesheim

P.F. 10 13 20, Steven 3
D-31113 Hildesheim-Bavenstedt Germany
Tel: 49.5121.762.40
Fax: 49.5121.762.496

Customer Team U.K.

15 New Star Road
Leicester LE4 9JD England
Tel: 44.0116.274.3660
Fax: 44.0116.274.3666

Customer Team Naples

Via San Nullo 171
80014 Giugliano (Na) Italy
Tel: 39.81.804.8852
Fax: 39.81.804.8854

Customer Team Paris

P.A. de la Danne - Eragny
B.P. 14-95611
Cergy-Pontoise Cedex - France
Tel: 33(0)1.34.32.30.30
Fax: 33(0)1.30.37.12.69

Customer Team Toulouse

Victoria Center
20 Chemin de Laporte
31300 Toulouse - France
Tel: 33(0)5.34.50.57.60
Fax: 33(0)5.61.49.04.19

• INDUSTRIAL OFFICES •

Customer Team Saint Cosme

9 Rue des Cressonnieres, BP 5
72110 Saint Cosme en Vairais France
Tel: 33(0)2.43.31.41.00
Fax: 33(0)2.43.31.41.41

Customer Team Kelkheim

Industriestraße 6
D-65779 Kelkheim Germany
Tel: 49.6195.8050
Fax: 49.6195.5647

Customer Team U.K.

15 New Star Road
Leicester LE4 9JD England
Tel: 44.0116.274.3660
Fax: 44.0116.274.3666

Manufacturing Facilities

Industry: Unruh

Screwcorp / Voi-Shan
135 North Unruh Avenue
City of Industry, CA 91744 USA
Tel: 626.937.5400
Fax: 626.937.5454

Santa Ana

Delron / Rosán
3130 West Harvard Street
Santa Ana, CA 92704 USA
Tel: 714.641.8800
Fax: 714.641.8801

South Bay

Camloc / RAM / Tridair / Voi-Shan
3000 West Lomita Boulevard
Torrance, CA 90505 USA
Tel: 310.784.2600
Fax: 310.784.6606

Kelkheim

Camloc / Tridair
Industriestraße 6
D-65779 Kelkheim Germany
Tel: 49.6195.8050
Fax: 49.6195.5647

Guarda

Eurosim / Simmonds
Parque Industrial da Guarda
Lotes 53/54 6300 Guarda Portugal
Tel: 35.10.712.22007

Fullerton

Kaynar / Eagle
800 S. State College Blvd.
Fullerton, CA 92831 USA
Tel: 714.871.1550
Fax: 714.680.0175

Fullerton: Plant 2

K-Fast / APS
801 S. Placentia Ave.
Fullerton, CA 92831 USA
Tel: 714.738.3600
Fax: 714.278.9900

Placentia

Microdot
190 West Cowther Avenue
Placentia, CA 92670 USA
Tel: 714.870.6650
Fax: 714.524.5346

Stoughton

Marson
44 Campanelli Parkway
Stoughton, MA 02072 USA
Tel: 800.343.3633
Fax: 800.644.2177

Ontario

Mairoll
747 E. Francis Street
Ontario, CA 91761 USA
Tel: 909.947.3366
Fax: 909.947.4866

Saint Cosme

Simmonds
9 Rue des Cressonnieres, BP 5
72110 Saint Cosme en Vairais
France
Tel: 33(0)2.43.31.41.00
Fax: 33(0)2.43.31.41.41

Hildesheim

Mecaero / Rosán / Screwcorp / Voi-Shan
P.F. 10 13 20, Steven 3
D-31113 Hildesheim-Bavenstedt
Germany
Tel: 49.5121.762.40
Fax: 49.5121.511.500

Roques

Mecaero
Boulevard du Grand-Castaing
Roques-eur Garonne
31128 Portet - Sur - Garonne Cedex
France
Tel: 33(0)5.61.51.82.30
Fax: 33(0)5.61.51.60.78

Montbrison

SNEP
BP 84 - 42602
Montbrison Cedex France
Tel: (33) 77.58.17.18
Fax: (33) 77.58.57.72

Oakleigh

Recoil
20 Stamford
Road, Oakleigh Vic. 3166
Australia
Tel: 61.3.9563.1500
Fax: 61.3.9563.1980

Fémipari KFT .

8248 Nemesvámos, Hungary
Dózsa György u. 2/a
Tel: 36.06.88.265.801
Fax: 36.06.88.265.802

Industry: Temple

Screwcorp / Voi-Shan
13001 Temple Avenue
City of Industry, CA 91746 USA
Tel: 626.369.3333
Fax: 626.369.3416

Conches

Mecaero
Zone Industrielle - BP 9
27910 Conches, France
Tel: 33.32.30.11.45
Fax: 33.32.30.98.06

Integrated Product Service Solutions

Fairchild Fasteners Direct

20660 Nordhoff Street
Chatsworth, CA 91311 USA
Tel: 818.998.1412
Fax: 818.407.5945

Part of Fairchild Fasteners

Fairchild Fasteners Direct: Germany

Robert-Bosch
Straße 4
D-86551 Aichach Germany
Tel: 49.8251.8757
Fax: 49.8251.513.11

Part of Fairchild Fasteners

Fairchild Fasteners Direct: France

P.A. de la Danne - Eragny
B.P.14 - 95611 Cergy-Pontoise Cedex
France
Tel: 33.1.34.32.55.33
Fax: 33.1.34.32.55.30

Part of Fairchild Fasteners

Fairchild Fasteners

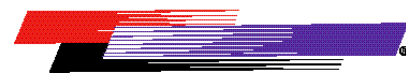

www.fairchildfasteners.com